

# Time Domain Simulator

## Application Note 1: Harmonic generation using a step recovery diode and a filter circuit.

In this example, we use the new WAVEFORM software to predict the waveform from a harmonic generator circuit consisting of a silicon step recovery diode (SRD) followed by an edge coupled microstrip filter. The simplified circuit topology is as shown in the next screen image.

This document is saved as appnote1.doc.

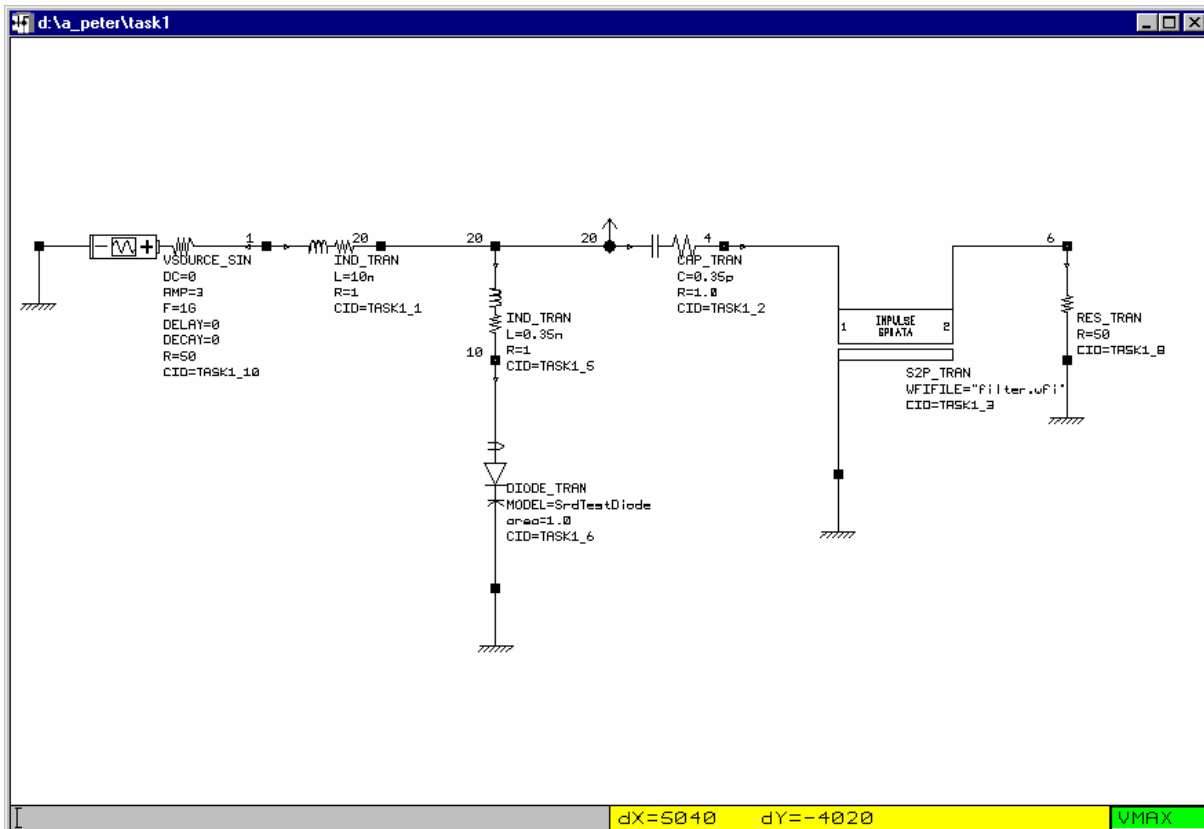

On the left hand side, we have a 50 ohm source impedance, 1.0 GHz sine wave generator sending the 3.0 volt signal into a 10 nH inductor. The SRD is connected to the 10 nH inductor through a short, low inductance 0.35 nH bond wire. The SRD is envisaged to be in the form of a chip in order to avoid any performance degradation that might occur were the chip to be packaged.

The diode model that is supported in WAVEFORM is the SPICE compatible PN junction diode, the diode parameters being:

```
SrdTestDiode
  device=diode
  IS=1.0E-16
  RS=5
  N=1.0
  TT=10N
  CJO=0.4P
  VJ=0.65
  M=2.5
```

The diode parameters have their usual meanings. It must be pointed out that the TT or “transit time” term is in fact the “diffusion time constant” rather than the transit time for the carriers across the depletion region. It is this term that also determines the magnitude of the diffusion capacitance for a forward biased PN junction.

Consequently, the 10 nSec value for the diffusion time constant in a silicon PIN junction diode is simply indicative of the stored charge when the diode is forward biased. It is well known that the SPICE PN junction diode does not accurately model the complex effects in a PIN diode, but we will use this simple model to illustrate the use of the WAVEFORM simulator in the prediction of waveforms in a circuit in which strongly non-linear effects are present together with linear circuit elements defined through the use of S parameter data.

The small value 0.35 pF capacitor that separates the SRD from the subsequent edge coupled filter is used to block the 1.0 GHz signal from the source. In like manner, the 10 nH inductor between the signal source and the SRD will stop the very high frequency components generated by the SRD from finding their way back into the signal source.

The passband filter is of the edge coupled microstrip variety, the topology of which was defined by the filter synthesis program called FILSYN. We chose a passband center frequency of 5.0 GHz, since we were interested in the generation of the 4<sup>th</sup> harmonic of the 1.0 GHz fundamental signal. The S parameter characterisation of the edge coupled microstrip filter was performed by the Optotek MMICAD software, with the simulated response predicted in uniform frequency steps up to 50 GHz. The predicted response is as shown in the next screen image.

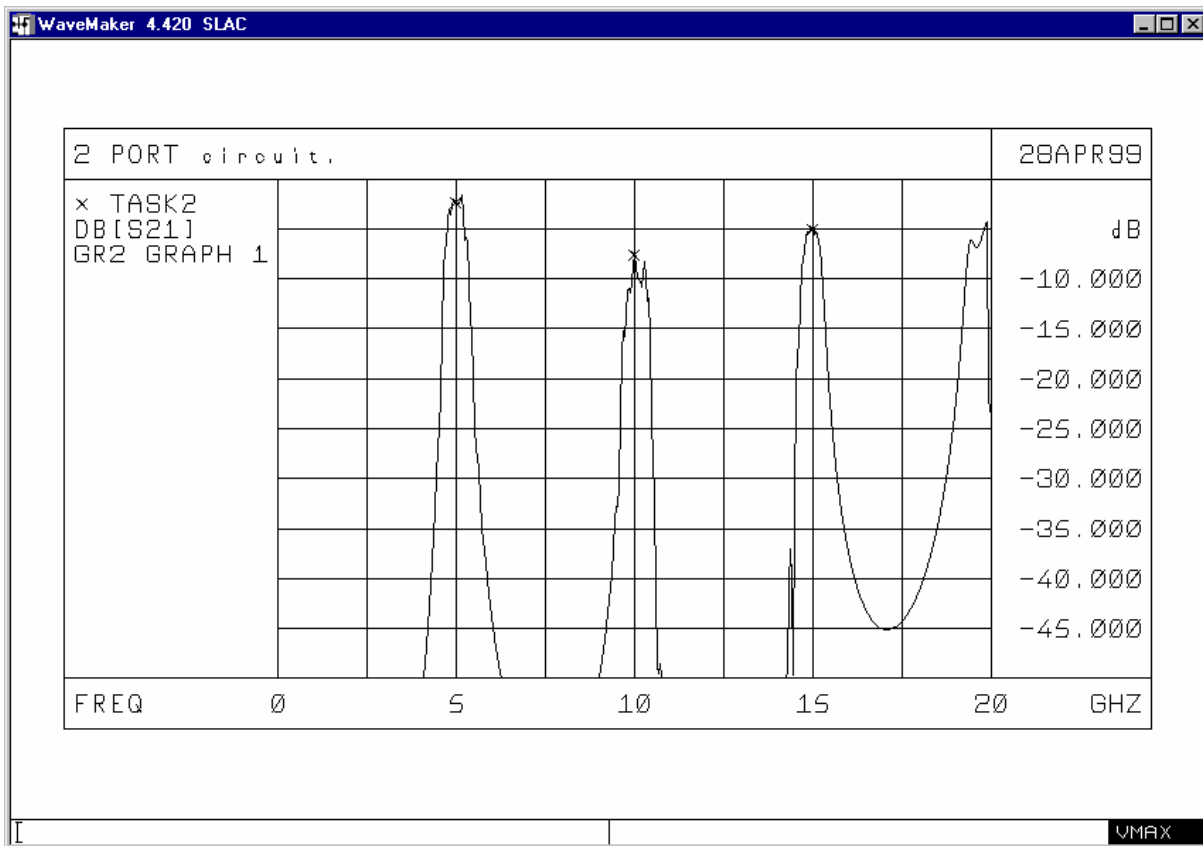

Any S parameter data that might be used in a simulation performed through the use of the WAVEFORM software needs to be converted into the time domain equivalent form of the data through the use of the stand alone IMPULSE utility. If the circuit appears to display very low losses, the IMPULSE software will add a small amount of loss to ensure the convergence of the time domain simulator when the processed S parameter data is used. The user can tell IMPULSE not to add any series resistance, should this be necessary. IMPULSE is a character mode executable “engine” that reads the data in the S parameter file, and creates a new file containing the time domain equivalent impulse response data: hence the name “IMPULSE” for this utility.

The time domain impulse response of the filter (the time domain equivalent of the S parameter data set) can be visualised, the the H21 (equivalent of S21) response as shown in the next screen image.

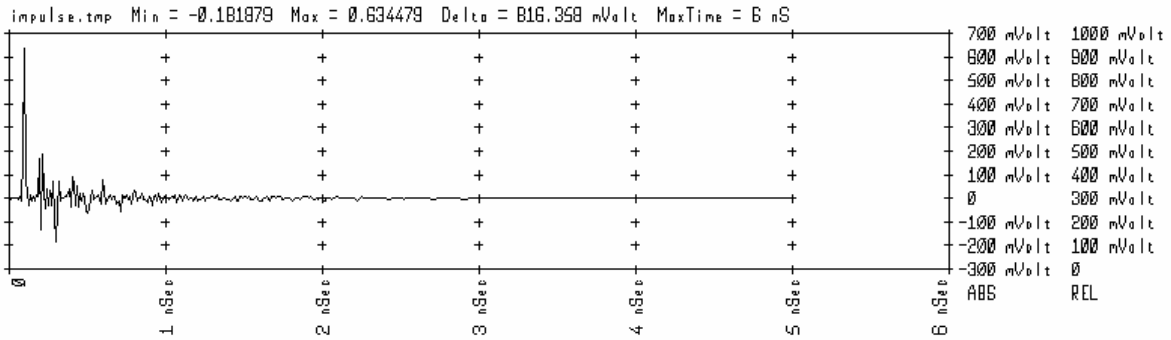

Notice in the above image that the impulse response dies away with time.

In order to simplify the situation, we first “fire up” the SRD based circuit with a 50 ohm load replacing the series combination of the band pass filter and the 50 ohm load. In this way we should be able to visualise the very, very non-linear waveform that is generated by the abrupt ending of the free carrier sweep out in the silicon SRD as the diode is moved into negative bias.

We define the total simulation time period to range from 0 to 20 nSec, with the software performing a prediction at least at every 10 pSec time interval.

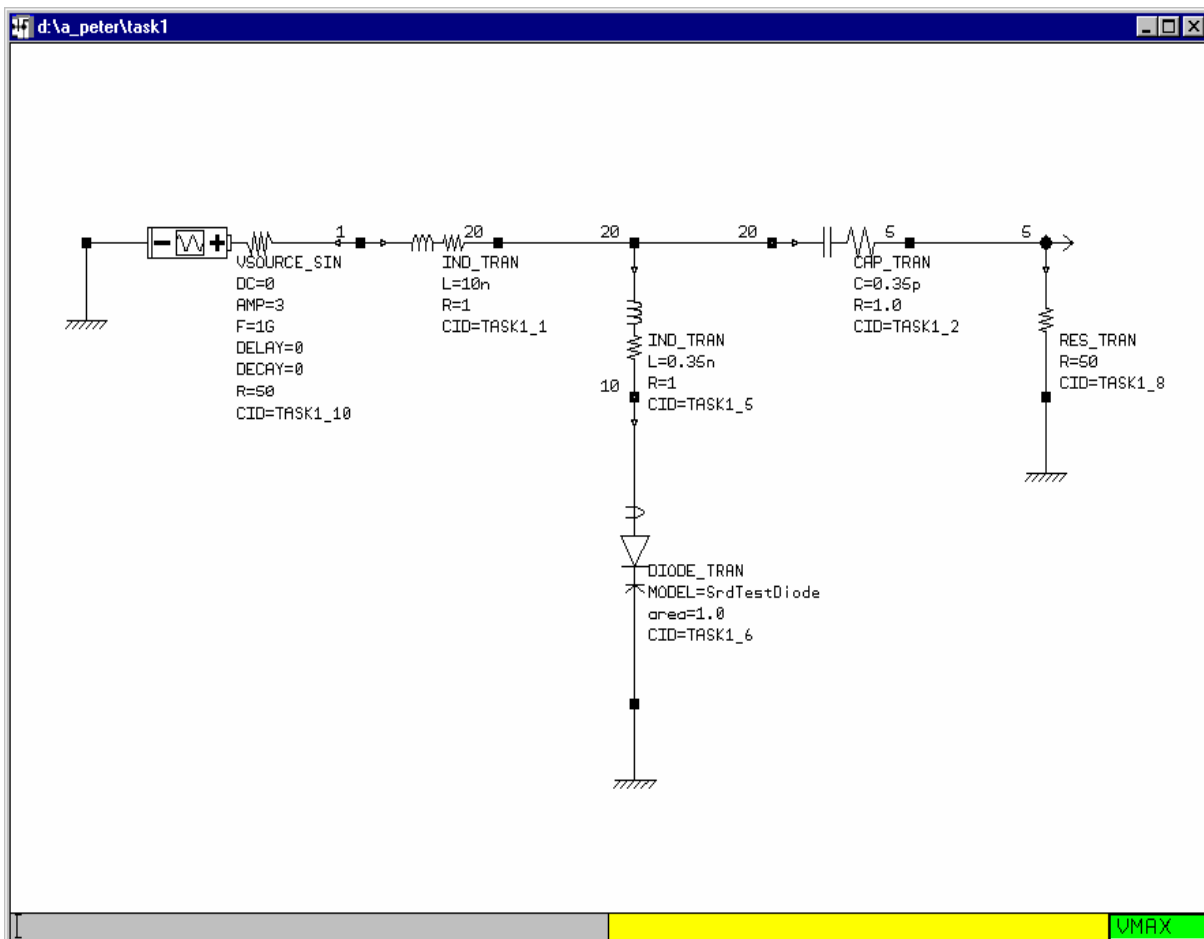

```

D:\WAMWORK\waveform.exe

Runtime statistics for task1.

Total number of devices: 7.
Total number of nodes: 6.

Setup time: 0.06 s.

Total analysis time: 8.83 s.
DC analysis time: 0.01 s.
Transient analysis time: 8.82 s.
Transient analysis time points: 2001.
Average transient analysis time per time point: 0.004 s.

Total iterations: 135015.
DC iterations: 203.
Transient iterations: 134812.
Average transient iterations per time point: 67.4.

Final OR factor 1.850.

Press return to continue.

```

The WAVEFORM simulator is also a character mode simulation “engine”, in essence transforming a circuit netlist as derived from either schematic capture, or as constructed through the use of a text editor, to a data file containing the predicted waveform data for each node in the circuit. After a simulation run, the software posts the simulation statistics, as shown above.

The screenshot shows the WAVEFORM simulator interface. At the top is a menu bar with options: FILE, INOUT, EDIT1, EDIT2, VIEW, POINTS, MACROS, SHAPES, LAYERS, SETUP, STYLE, HELP, COMMON, SCHEM2. Below the menu is a toolbar with icons for various functions. The main window displays a circuit schematic with components like USOURCE\_SIN, INDUCTOR, CAPACITOR, and DIODE. A VPROBE component is placed at the leftmost node of the circuit. A command menu is open on the left side, listing various simulation and editing commands. The VPROBE command is highlighted in green. At the bottom, there is a status bar showing the current file (task1.sym) and coordinates.

By assigning the VPROBE command to the left most mouse button, the user can then click that mouse button with the mouse cursor at any node to view the predicted waveform at that node. With such a capability, the user does not need to know, or see, any of the node numbers, even though they are displayed on the circuit schematic.

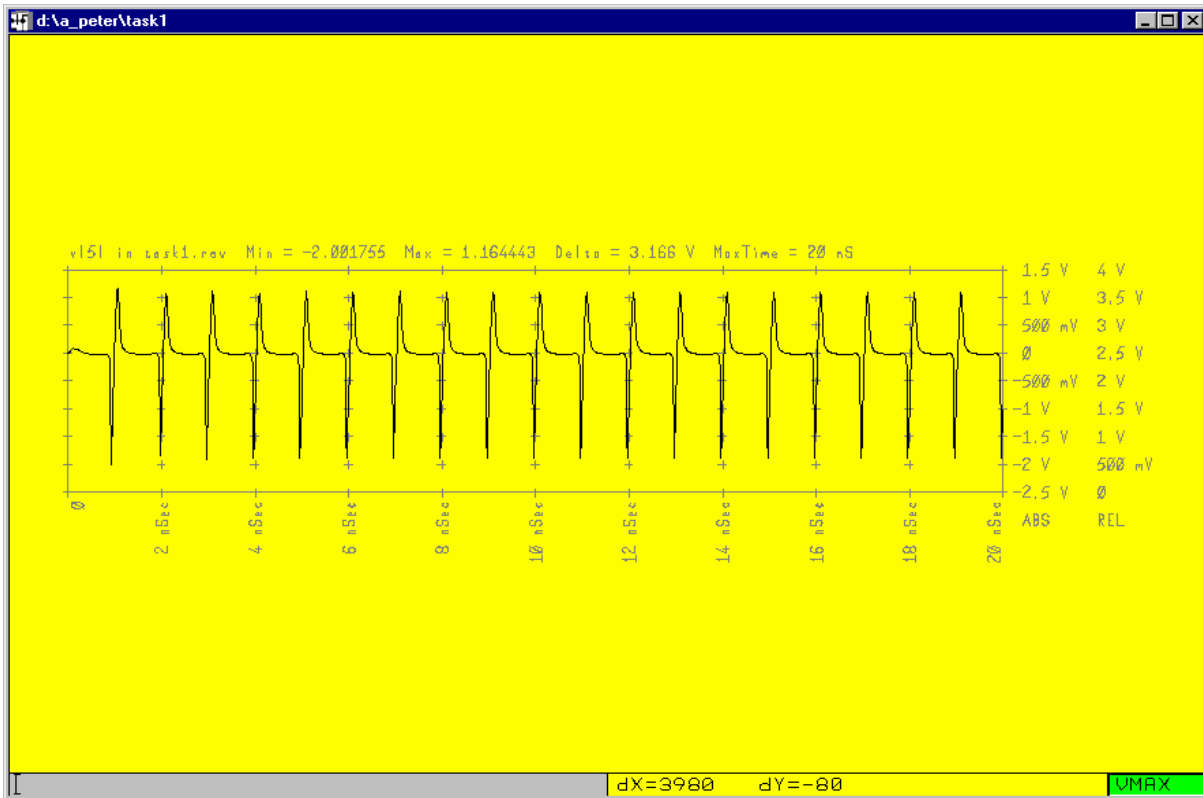

Without further ado, we probe the voltage across the output 50 ohm load, and the software temporarily superimposes the plot of the predicted waveform over the circuit schematic, as shown above. If we probe the voltage at the node between the signal source and the series 10 nH inductor, as shown below, we see that our circuit has not been totally effective in blocking the signals generated by the SRD from reaching the source.

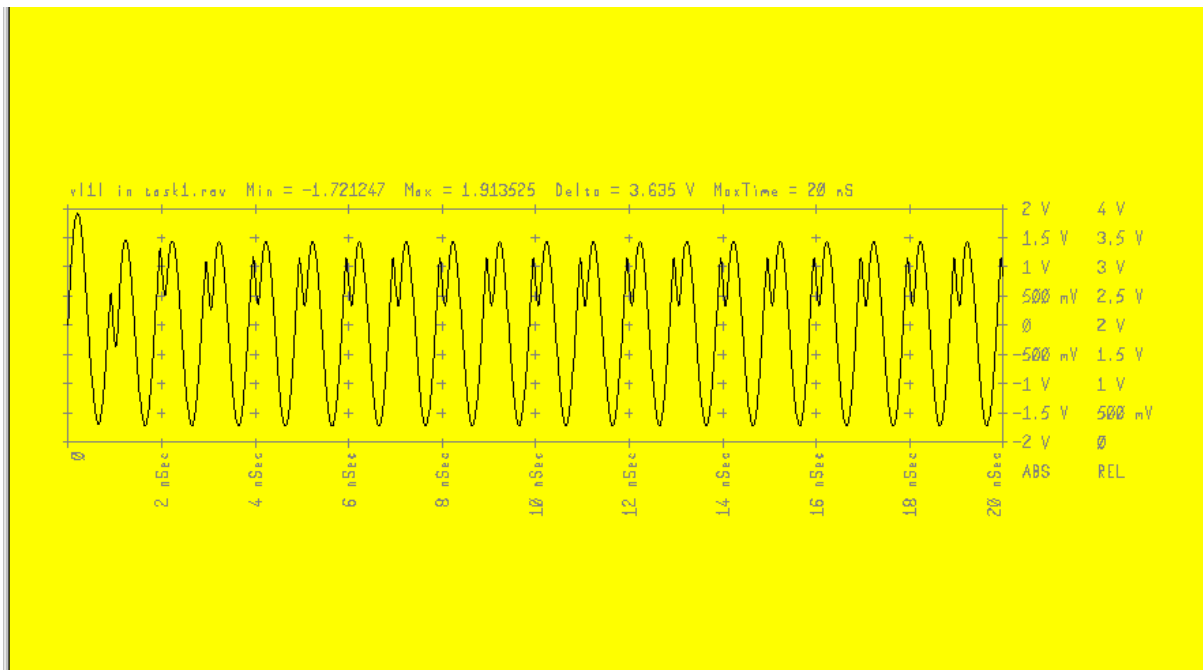

Since the aim of this application note is to illustrate the use of the novel time domain simulator we have developed, as opposed to discussing the ways in which one can design a high performance SRD based harmonic generator, we will leave the circuit as it is, and next attach the edge coupled band pass filter, as shown next.

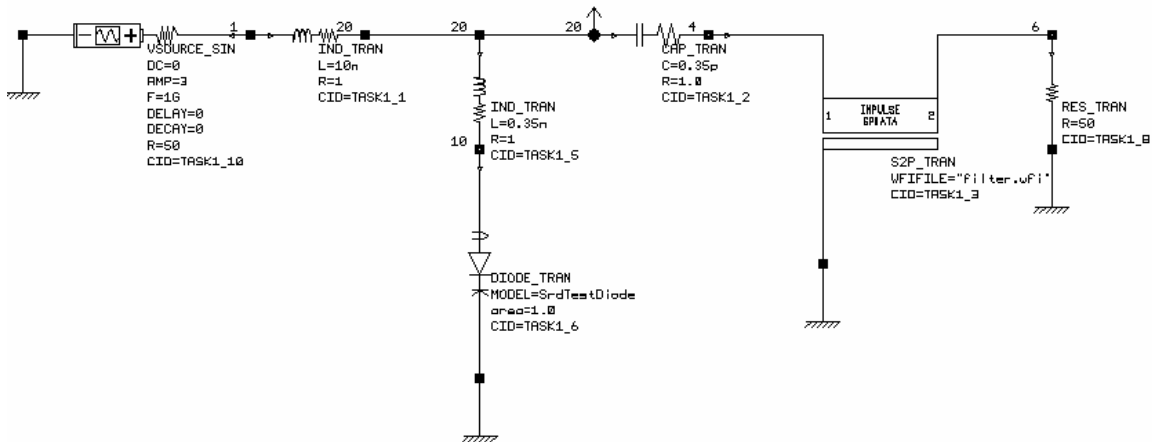

The response of the edge coupled filter is as defined in the filter.wfi file, which was generated through the use of the IMPULSE software from the filter.s2p file. Although in this example we have mapped the filter.s2p data in the frequency domain to the filter.wfi file in the time domain, we will in future map the filter.s2p data to the filter.h2p equivalent impulse response data file.

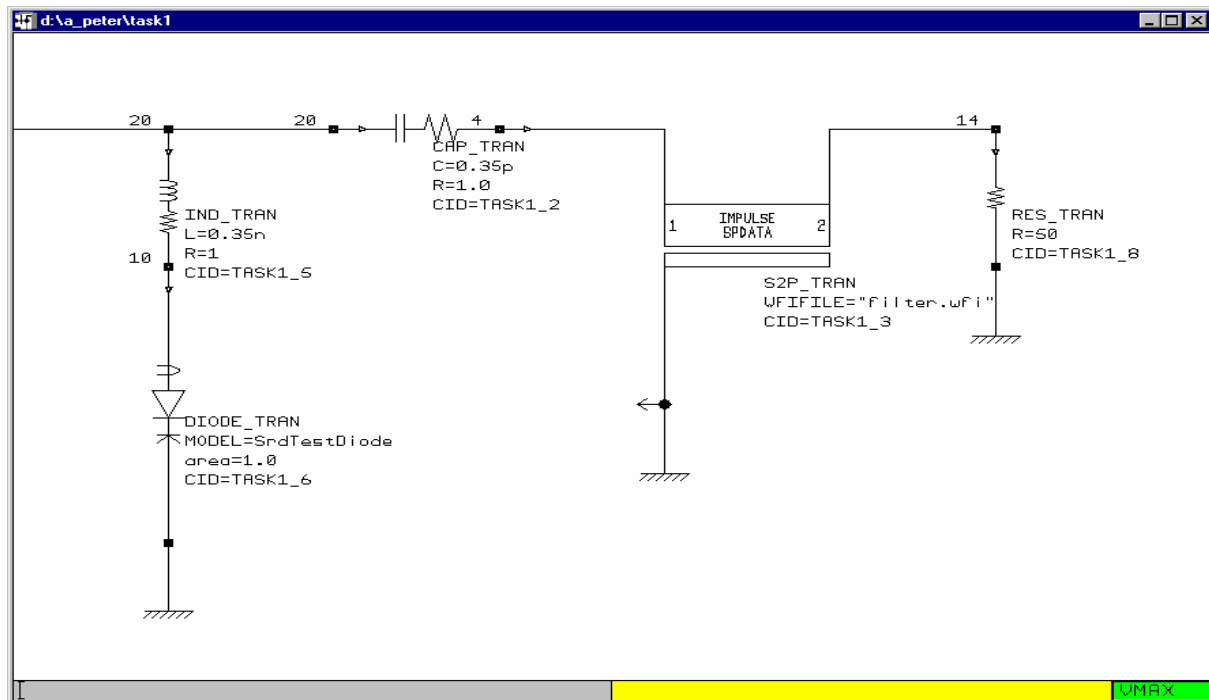

The output part of the circuit is as shown above.

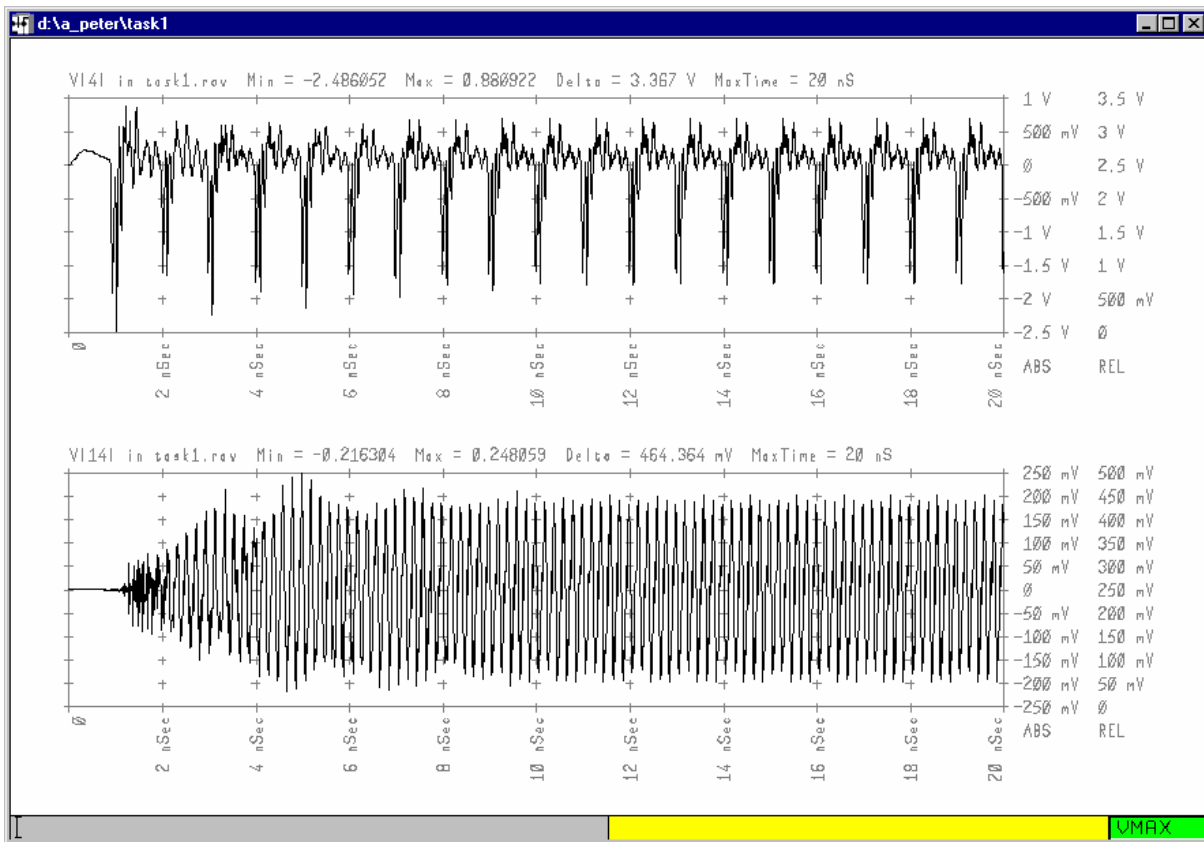

In the above screen image, we show the waveform (upper plot) at the input to the edge coupled filter, and (lower plot) at the output from the edge coupled filter and across the 50 ohm terminating load resistance.

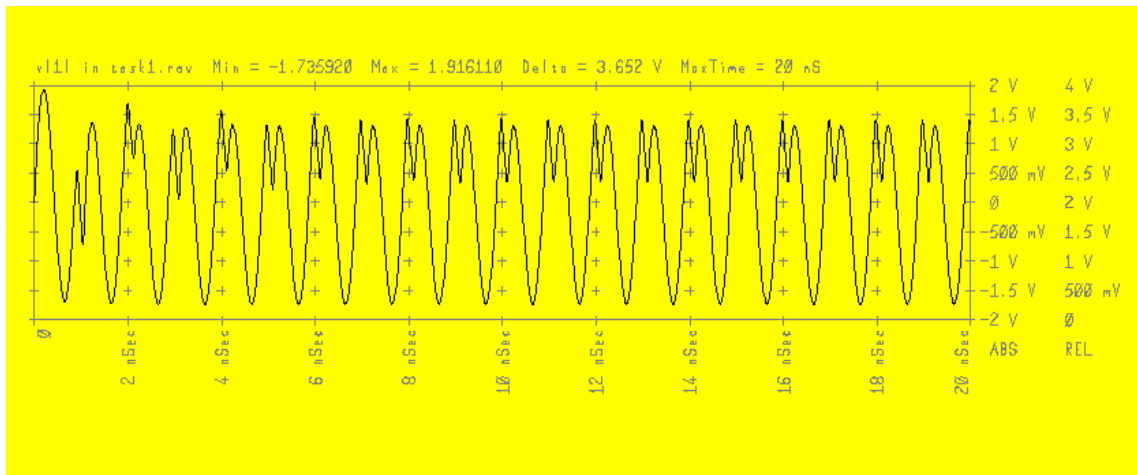

Compared to the signal at the input to the series 10 nH inductance at the input to the SRD circuit, as shown above, we see that there is some appreciable signal at the fifth harmonic being generated by the SRD based circuit.

As a point in passing, although the actual signal source in series with the 50 ohm source resistance is generating a sine wave with an amplitude of 3.0 volts, in effect

the amplitude of the signal from the signal source including the effect of the source impedance is 1.5 volts. The amplitude of the 4<sup>th</sup> harmonic at 5.0 GHz is 200 mV, as seen in the upper screen image.

In order to investigate the characteristics of the waveform in the spectral domain, we use the REFORMAT command to take a sample of the signal from 9.0 nSec to 19.0 nSec, and then make use of the FFT based SPECTRUM command to display the predicted spectral response of the signal from the SRD based circuit.

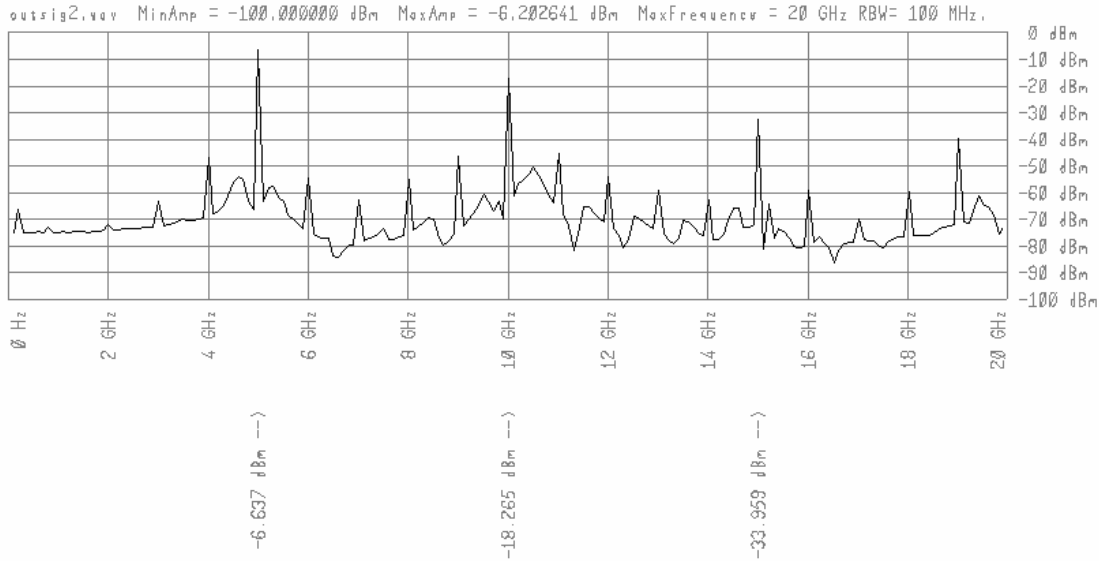

We have instructed the software to calculate the amplitude in dBm (50 ohm system) of the first three harmonics, as shown in the screen image above. The predicted signal levels are:

1 <sup>st</sup> harmonic	- 6.637 dBm
2 <sup>nd</sup> harmonic	-18.265 dBm
3 <sup>rd</sup> harmonic	-33.959 dBm

The level of the source 1.5 volt amplitude in dBm into a 50 ohm load is about 16.5 dBm.

The interesting point we would like to make with this example is that with this new software one can perform the simulation of the waveform at any node in a circuit containing a mix of non-linear and linear devices, with the electrical characteristics of some or all of the linear devices being defined through the use of measured or predicted S parameter data. As shown in this example, the circuit non-linearities can be severe, and still the software is able to predict the waveforms in the circuit. Since use can be made of S parameter data to characterise the response of the linear circuit elements, the software can accurately incorporate complex effects such as the skin

effect and frequency dispersion in the effective dielectric constant of a microstrip line.

Through the use of the Fast Fourier Transform on a sample of the waveform after the initial transients are more settled, we can get an idea of the steady state response of the circuit, including an indication of the level of any harmonics generated. We believe that this software contributes to improving the applicability of software based solving the circuit response in the time domain to the simulation of microwave and fast optoelectronic circuits. As such, this simulator more effectively compliments the capabilities of simulators based on the principle of harmonic balance that are used to predict the steady state response of microwave circuits.