

The prediction of non-linear waveforms
in fast microwave and optoelectronic circuits
through the use of a new time domain simulator.

by
Dr Joseph A. Barnard and Michael Taylor
Barnard Microsystems Limited

April, 1999

134 Crouch Hill
London, N8 9DX, U. K.

TEL: +44 208 341 0566
FAX: +44 208 341 0583

email: bml@compuserve.com
www.barnardmicrosystems.com

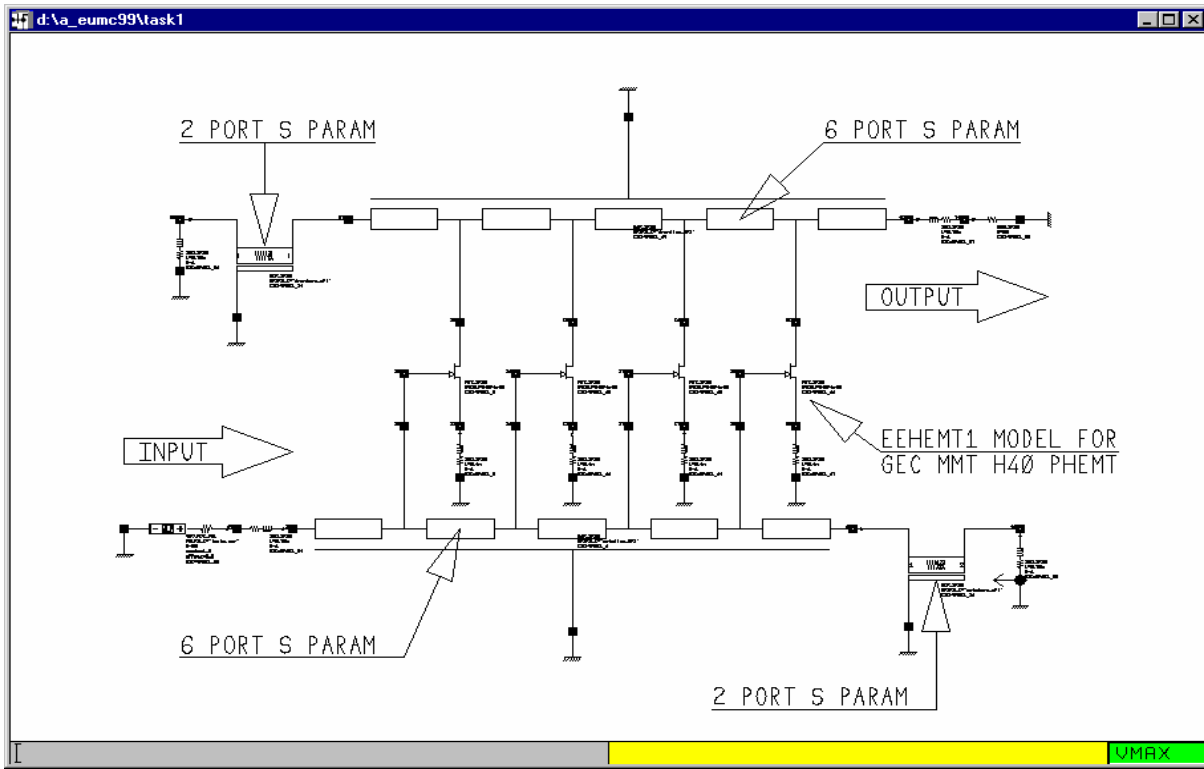

Use of S parameter data in GaAs travelling wave amplifier MMIC. The S parameter data is created through the use of an electromagnetics based simulator.

Abstract

A time domain simulator has been developed for use in the prediction of waveforms in a fast, microwave circuit in which **accurate S parameter data** can be imported and used in the simulation.

This capability allows us to **include complex, frequency dependent effects in passive circuits**, such as the variation of effective dielectric constant and loss of a microstrip line with frequency for a broad band microwave circuit. Since the simulator can import S and Y parameter data for passive networks with up to 19 ports, we can make use of advanced electromagnetic simulators to predict the transfer response for the passive circuitry external to an MMIC, and so predict the effects of both the packaging (such as the coupling between bond wires) and interactions between the MMICs that are connected using short length of microstrip lines. We have used this unique software to predict the EYE diagram for a GaAs MMIC containing more than 70 PHEMTs, more than 70 diodes and over 20 six port travelling wave structures. The agreement between the predictions for a 10 GBit/sec NRZ PRBS, large signal drive level, and the measured response is excellent.

To ensure an accurate simulation, we have included **advanced GaAs FET models**, such as the EEHEMT1 and TOM3 models, in addition to the SPICE diode. The extraction of the EEHEMT1 or TOM3 parameters for an arbitrary PHEMT is still problematic, simply because of the scarcity of parameter extractors for these models.

Externally defined waveforms as encountered in the microwave and optical communications worlds, can be used to control voltage and current sources.

We have run this simulator on circuits with up to 3,328 GaAs PHEMT based IC at 10 GBit/sec to test the ruggedness of the simulator. In addition, this simulator has operated correctly on waveforms with rise times as short as 1 psec. We have established some rules for the form of the S (or Y) parameter data that the simulator requires.

We use this simulator in the following areas:

- to predict the performance of circuits in which travelling wave structures are used, typically in circuits operating at 40 and 160 GBit/sec;
- in the prediction of the effects of packaging, MMIC-to-MMIC interaction, and MMIC-to-active device interaction, including all microwave circuit discontinuities. We typically use a combination of measured S parameter data (eg. for the thin film passive chip components and any connectors) and S parameter data as predicted through the use of 2.5D and 3D electromagnetic simulators;
- in the simulation of the effects to be found in step recovery diode based circuits, non-linear transmission lines and related sampling circuits in which very fast diodes are used.

In order to maintain a balanced view of the capabilities of this software, it must be pointed out that:

- noise is not predicted by the non-linear simulator, although a linear equivalent circuit at the bias point is defined, from which the circuit noise can be predicted through the use of a linear microwave circuit theory based simulator;
- presently, bipolar transistors of any description are not supported;
- the simulation of modulated carrier systems is cumbersome at present.

1. The historic position

	Traditional Time Domain based SIM	Harmonic Balance based SIM
S Parameter import	✗	✓
Advanced GaAs FET and PHEMT models	✗	✓
Simulate strongly non-linear circuits	✓	✗
Can make use of complex waveforms (eg. PRBS 65,536 samples)	✓	✗
Predict <u>unintentional</u> oscillations in circuit	[with injected pulse]	✗
Can simulate modulated carrier situations	✗	[some can]
Can predict noise (including phase noise)	✗	[some can]

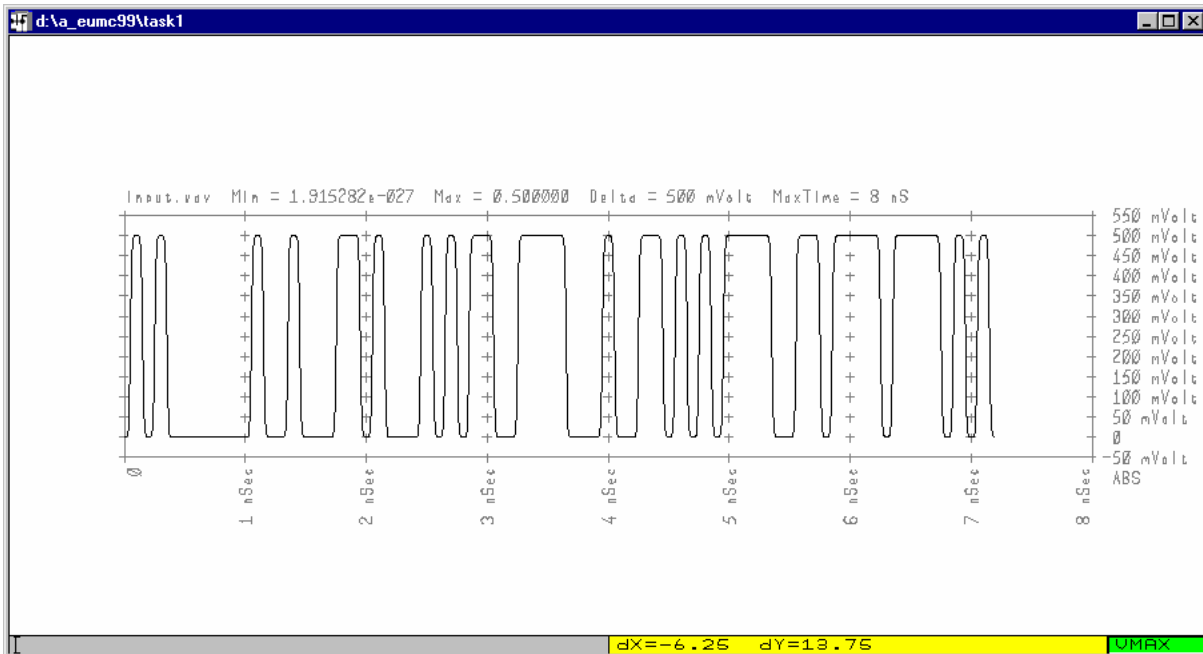

Example of “complex” waveform input to a circuit.

2. The design problem

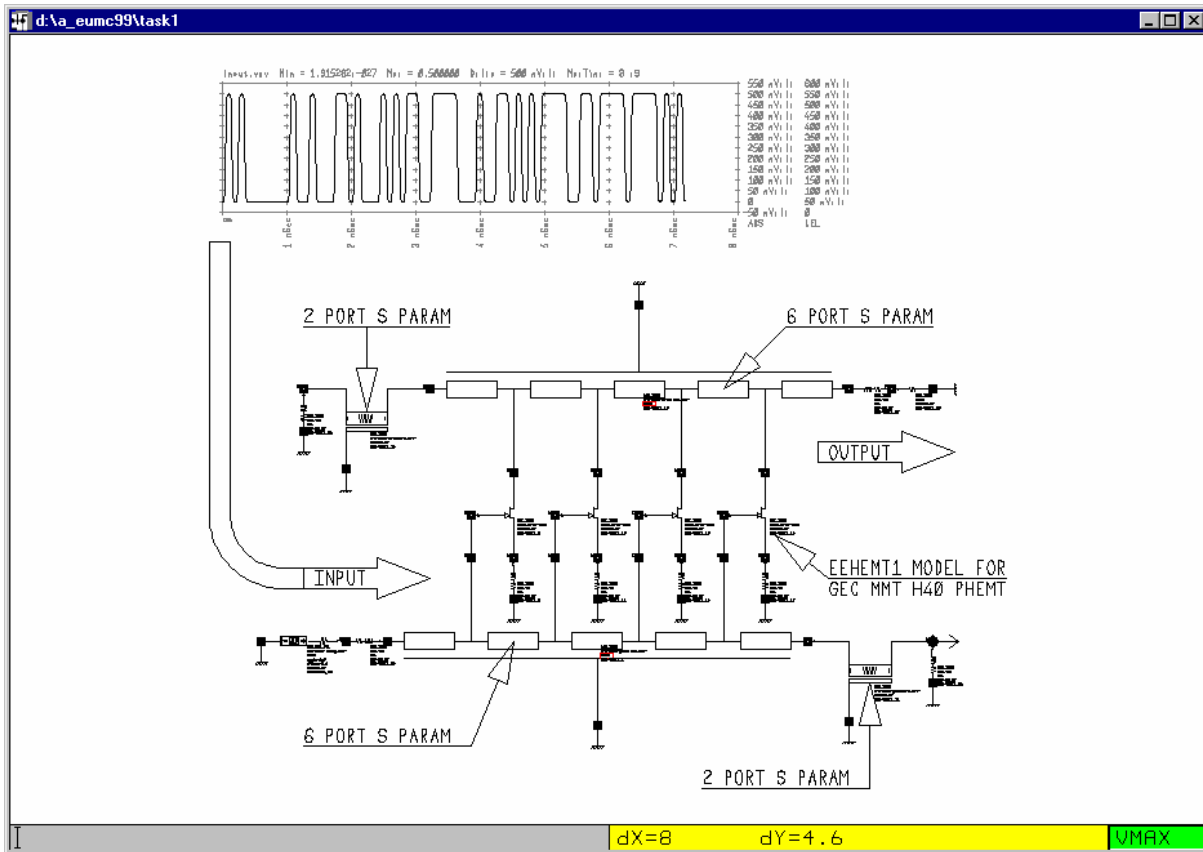

Predict:	TD	HB
■ accurately (ie. accurate description of <u>all</u> elements needed)	x	✓
■ the output waveform	✓	✓
■ of MMICs containing distributed passive structures	x	✓
■ and advanced non-linear devices such as PHEMTs	x	✓
■ when driven at “high level” (ie. <u>strongly</u> non-linear)	✓	x
■ by an external, complex, communications-type waveform	✓	x
■ including packaging effects	x	✓
■ and MMIC-to-MMIC interactions (eg. interconnects)	x	✓
Can the task be performed as specified?	x	x

We at Barnard Microsystems were not able to perform this task with the currently available software tools. Why? Traditional time domain sim problems encountered:

- only relatively inaccurate PHEMT models supported;
- need to approximate 6 port S parameter data as predicted through the use of an electromagnetics based SIM through the use of an “equivalent” RLC network (this was a really bad approximation!);
- inability to import S param data forced us to make drastic simplifications in the way we defined the packaging and external circuitry, so the predictions of the MMIC-to-MMIC interactions were both optimistic and wrong.

With the HP Impulse software, we experienced convergence problems, so we got no solutions from the use of this software. On the Harmonic Balance front, the problems were different:

- most importantly, inability to import a complex, communications-type driving waveform which might be sampled at from 2,048 to 65,536 time points
- inability to converge when use is made of a high level driving signal, causing the circuit to operate in a strongly non-linear regime
- inability to converge for “complex” circuit topologies, such as two Schottky barrier diodes in series, driven with a low level signal.

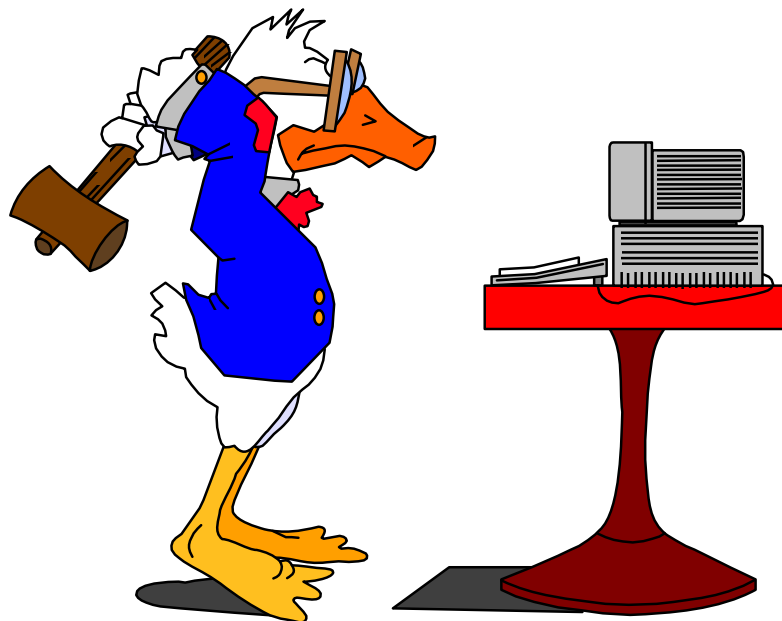

3. The solution

Develop a new simulator from scratch. The initial specifications were as follows:

- support the import of 1 to 19 port Y and S Parameter data sets
- support the EEHEMT1
TOM
TOM2
TOM3
and COBRA GaAs MESFET and PHEMT models
- must indicate whether a circuit will unintentionally oscillate without the use of any injected signals

The new simulator to be constructed as a two-component solution:

- the S parameter-to-impulse data converter (called “impulse”)
- the new time domain simulator itself (called “waveform”)

Each software component constructed as a stand alone executable running under Microsoft Windows 95/98, or, Microsoft Windows NT. The executable to be in the form of a character mode executable so that it will be easy and quick to port impulse and waveform to run under Linux. This capability should enable us to provide copies of the software that can run on very fast UNIX servers, should the requirement arise.

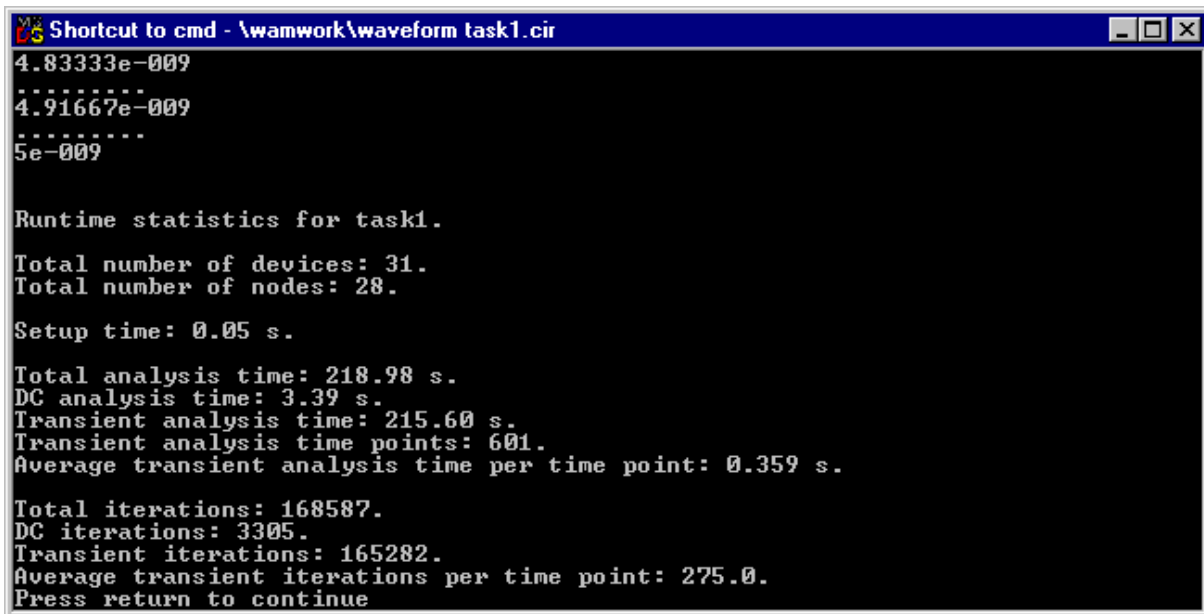

```
Shortcut to cmd - \wamwork\waveform task1.cir
4.83333e-009
*****
4.91667e-009
*****
5e-009

Runtime statistics for task1.
Total number of devices: 31.
Total number of nodes: 28.

Setup time: 0.05 s.

Total analysis time: 218.98 s.
DC analysis time: 3.39 s.
Transient analysis time: 215.60 s.
Transient analysis time points: 601.
Average transient analysis time per time point: 0.359 s.

Total iterations: 168587.
DC iterations: 3305.
Transient iterations: 165282.
Average transient iterations per time point: 275.0.
Press return to continue
```

At the end of a simulation, the waveform character mode executable displays a listing of the simulation statistics.

As far as we are aware, the only other commercially available simulator that supports this capability, albeit in a more limited manner, is the Hewlett-Packard Impulse software. We believe that the waveform software we have developed represents the state-of-the-art in terms of combining the accuracy of frequency domain simulation of passive circuit elements with the simulation in the time domain of the non-linear components using the best available models.

Additionally, the simulator supports the import of arbitrary length (number of time points), externally defined, waveforms used to control voltage and current sources

The output EYE diagram and other characteristics of a complex GaAs IC containing in excess of 20 six port travelling wave feed structures, in excess of 70 FETs and in excess of 70 Schottky barrier diodes has been accurately predicted. The S parameter data for the travelling wave structures was derived through the use of an electromagnetic simulator, so the details concerning the frequency dependent losses and frequency dependent changes in effective dielectric constant have been included in the time domain simulation. Prior to use of this new software, the six port feed structures had to be represented in the form of an RLC type circuit, and the predicted waveform was optimistic and incorrect.

With waveform, we are now able to account for package effects, such as coupling between the bond wires, and chip-to-chip interactions with the ICs being connected through the use of microstrip lines. The coupling between the bond wires is predicted through the use of an electromagnetic simulator.

At this stage in its existence, waveform is being used to great advantage in the design of GaAs ICs for use in 10 Gbit/sec optical communication modules, in improved microwave circuit package design and in the design of non-linear transmission lines.

We believe that this new simulator represents a major advance in the accurate prediction of the non-linear response of microwave circuits. The simulator was constructed with the top priority being robustness. The mathematical technique we have adopted does not require the simulator to perform any matrix inversions, so the waveforms in a circuit with a nearly singular linearized Y matrix can be accurately predicted. Our view is that this simulator compliments simulators based on the Harmonic Balance approach, and does not replace all of the functionality of the HB based simulators. Specific features not present in waveform include:

- support for Si BJT, GaAs HBT and Si MOSFET models
- the ability to predict phase noise
- the efficient prediction of the response of a circuit to a slowly varying sine wave (carrier wave envelope simulation).

4. The new position

The merits of this new simulator relative to other non-linear circuit simulators is summarised briefly in the next table:

	Traditional Time Domain based SIM	Harmonic Balance based SIM	New TD SIM
S Parameter import	×	✓	✓
Advanced GaAs FET and PHEMT models	×	✓	✓
Simulate strongly non-linear circuits	✓	×	✓
Can make use of complex waveforms (eg. PRBS 65,536 samples)	✓	×	✓
Predict <u>unintentional</u> oscillations in circuit	[with injected pulse]	×	✓
Can simulate modulated carrier situations	×	[some can]	×
Can predict noise (including phase noise)	×	[some can]	×

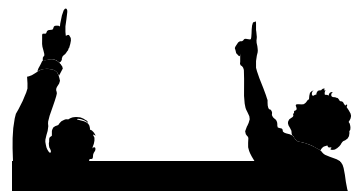

“That’s more like it!”

On a more detailed note:

In order to accurately predict the power out from an amplifier at mm wave frequencies, the PHEMT model needs to include a gm-related current generator with a delay that varies with internal $v_{ds}(t)$. Neglecting this effect results in an over optimistic prediction for the power output. It is our current understanding that the inclusion of such an effect in any HB based simulator is extremely difficult. Such an effect can be included in a time domain simulation, at the expense of simulator speed.

5. Predicting unintentional oscillations

We believe that, in general, an HB based simulator will not always, if ever, indicate that a circuit will oscillate unintentionally, if, for example, the circuit is meant to function as an amplifier.

Our understanding is that the best that one can hope for when an analysis is performed on a circuit that would unintentionally oscillate is that the simulator will not converge.

The inability of an HB based simulator to converge could also result from:

- the non-linear effects in the circuit being “too severe”, or
- a combination of driving conditions and a “difficult” circuit topology (such as two lightly driven, series connected diodes)

Consequently, a lack of convergence by an HB based simulator is not an unambiguous indication that the circuit will unintentionally oscillate.

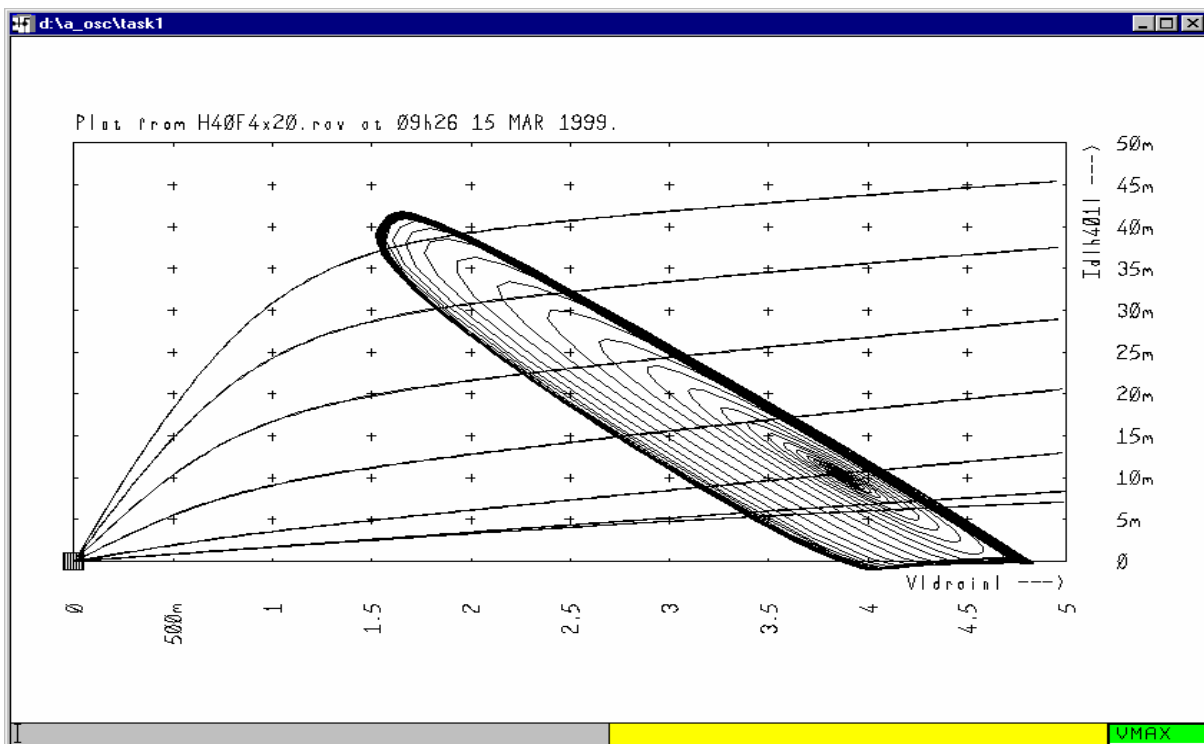

A fortunate consequence of the technique we use, which is different from that used in SPICE based simulators, is that there is always a low level random voltage signal at each node, very much analogous to the thermal noise present in any real electronic circuit. This low level signal, one microvolt or less in amplitude, causes the circuit to oscillate in situations in which it would unintentionally oscillate.

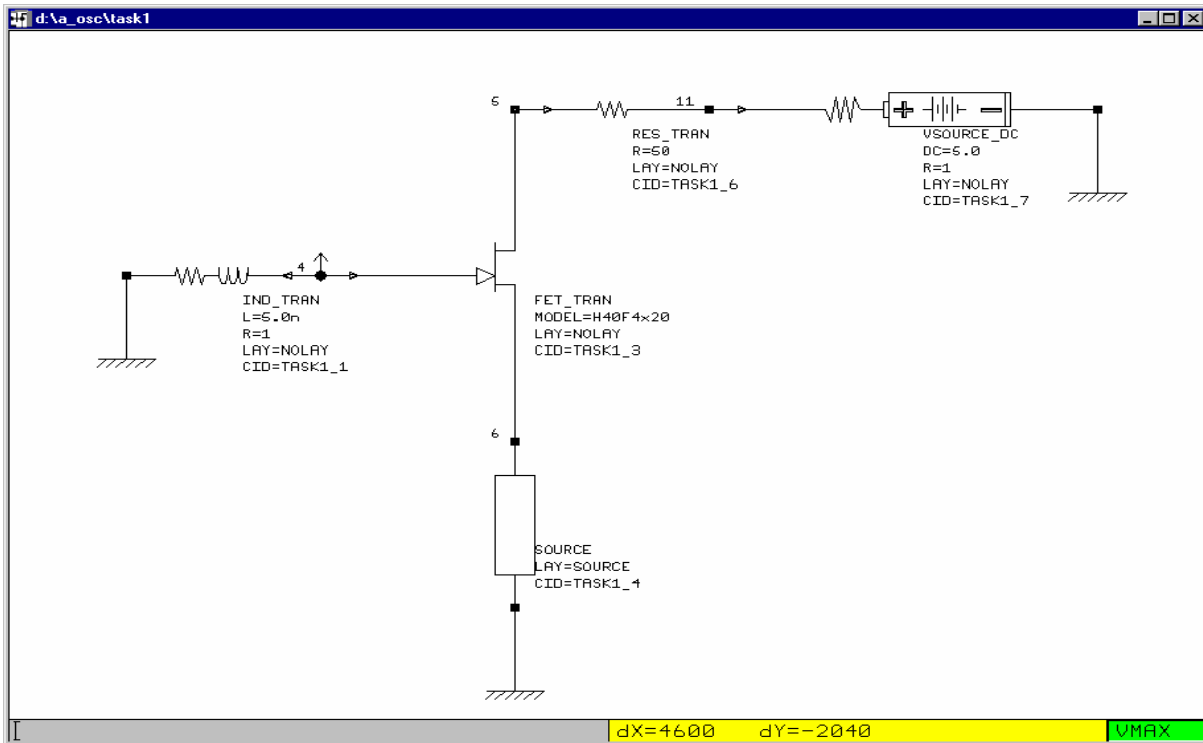

The circuit has an S parameter data section in the source of the GaAs PHEMT, and makes no use of injected pulses to start any possible circuit oscillations.

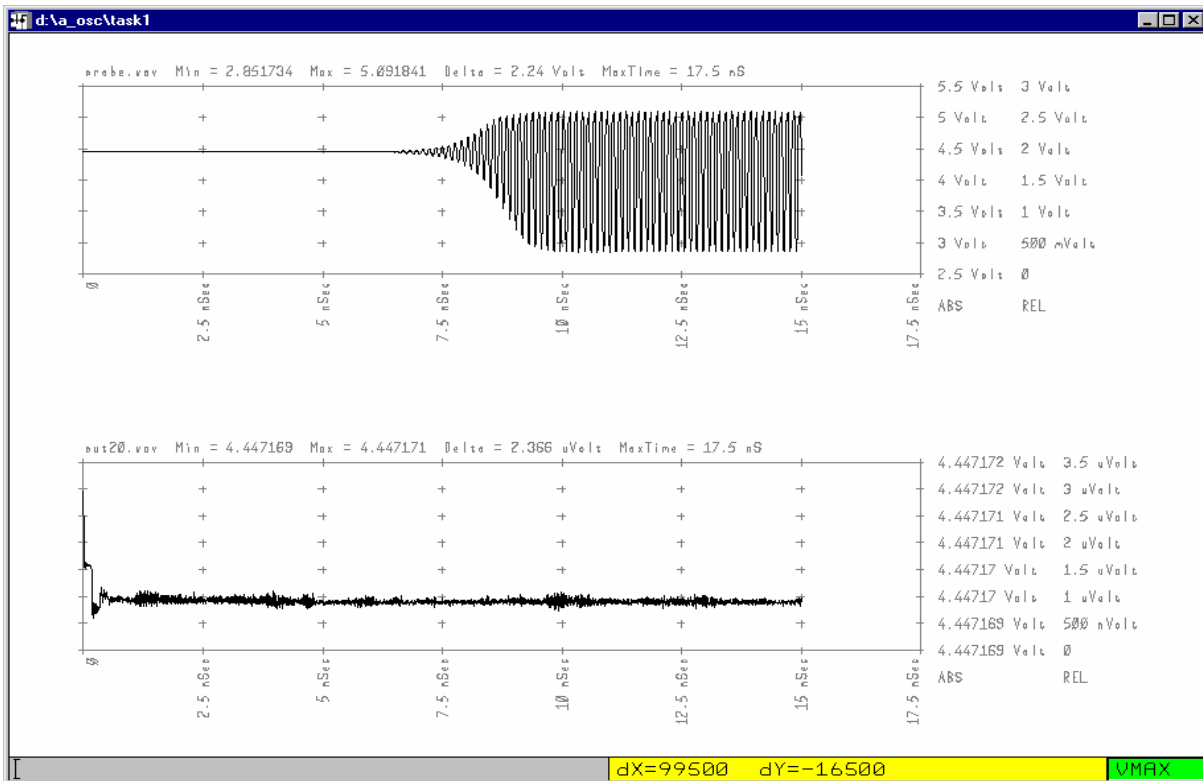

Upper trace: $L_g = 5.0 \text{ nH}$, no stimulus applied to cause oscillations (500 mV / DIV).
 Lower trace: $L_g = 0.5 \text{ nH}$, noise amplitude $\sim 150 \text{ nV}$ clearly visible (500 nV / DIV).

6. Investigating the waveforms in a strongly non-linear circuit

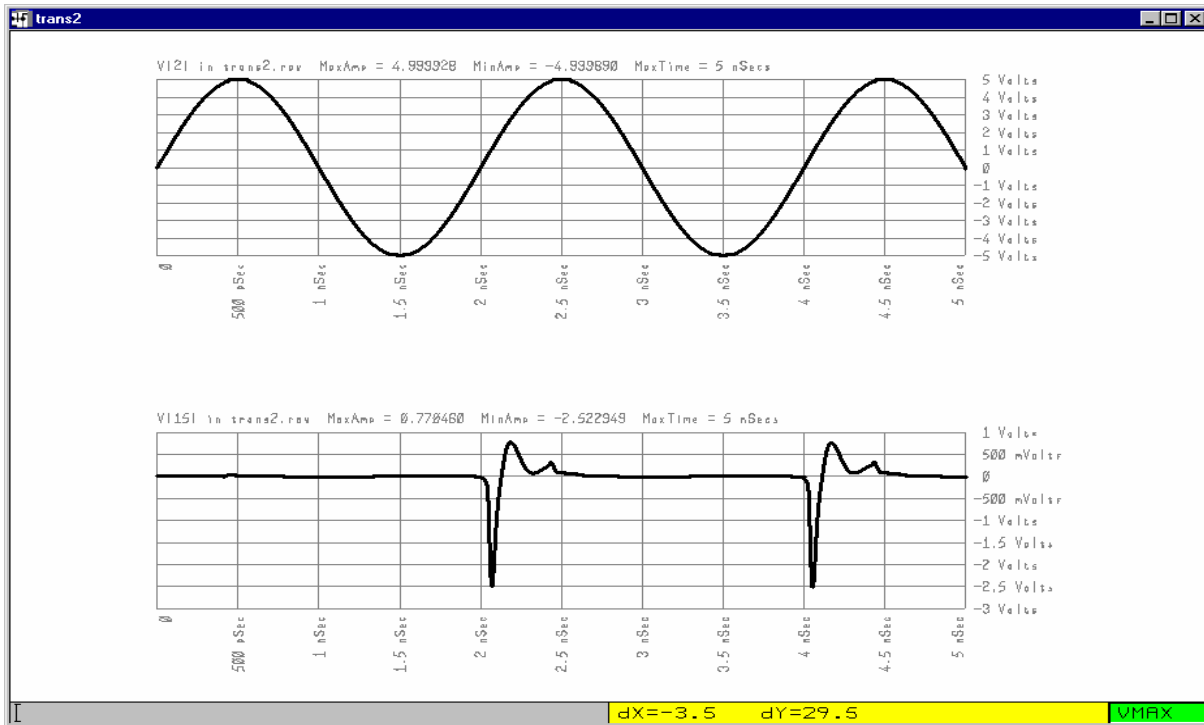

The predicted waveforms shown in the screen image above are taken from a circuit containing a step recovery diode. The input 500 MHz, 5 volts peak sine wave is applied across the silicon step recovery diode, and the characteristic sharp response is obtained at the output from the circuit.

This phenomenon results from the abrupt termination of carrier sweep out in the diode, and is used in harmonic generation and sampling circuits. The output waveform is clearly rich in harmonics, and is extremely non-linear.

Such an output response cannot easily be predicted through the use of a harmonic balance based simulator. The new time domain simulator, on the other hand, accurately includes all the details of the passive circuit and correctly manages the non-linear active elements.

On a technical note:

The classical SPICE based PN junction diode does not correctly model some of the fundamental, though complex, effects in the PIN diode. This deficiency is present in most time domain and harmonic balance based simulators. As part of our software development roadmap, we have scheduled efforts in July, August and September 1999 to add to the waveform simulator support for the following models: Schottky Barrier Diode, PIN diode, varactor (hyperabrupt) diode, Planar Barrier Diode and the Photodiode.

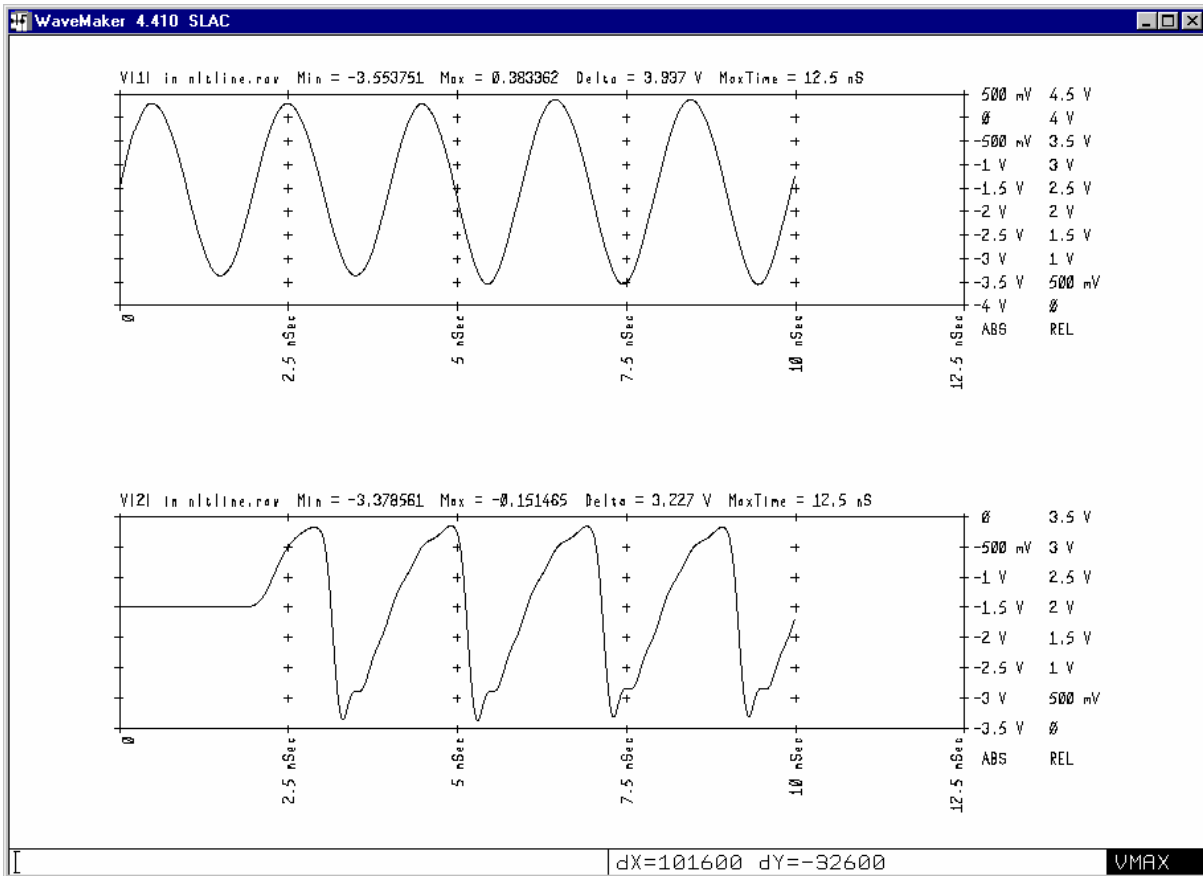
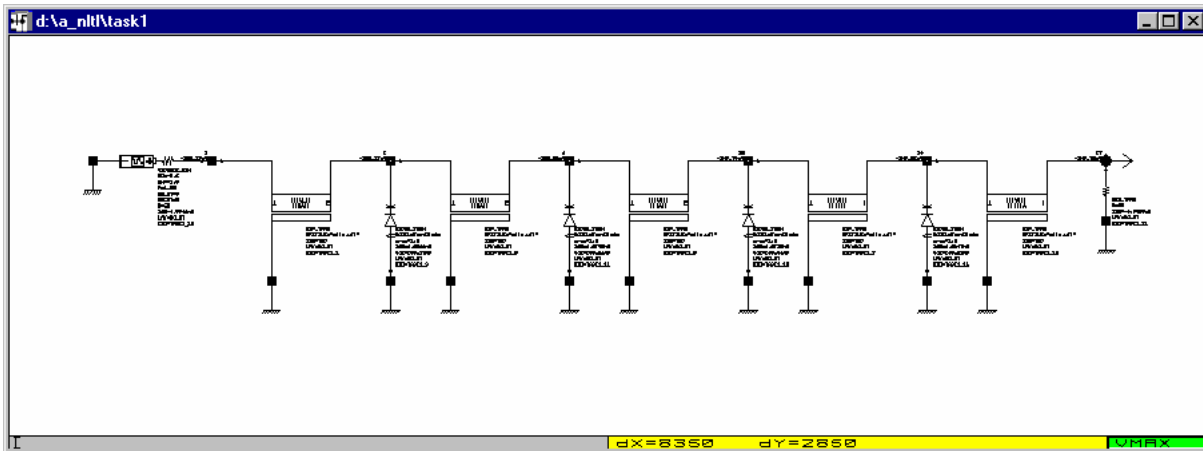

In the Non-Linear Transmission Line (NLTL), a series of Schottky barrier diodes (4 in schematic; 16 in the simulated response) are used to periodically load a coplanar transmission line. When a sine wave is sent down this line, the leading edge of the sine wave sharpens up, while the trailing edge displays a longer “fall time”. Again, many harmonics are associated with this non-linear phenomenon. The most important limiting factor is the skin effect losses of the passive transmission media.

A traditional time domain simulator will neglect the most important limiting phenomenon, and a harmonic balance based simulator will either not converge, or take a painfully 1...o.....n.....g time to perform a simulation.

7. How does it all work?

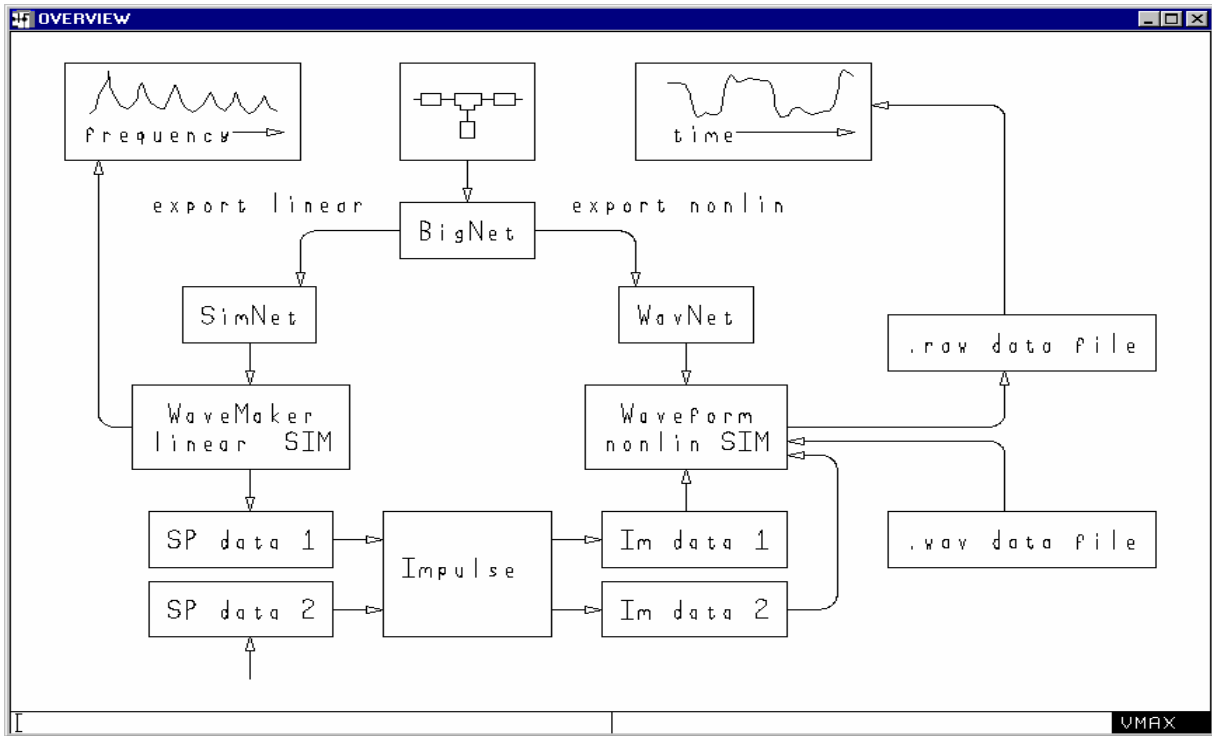

The linear and non-linear circuit netlist descriptions are derived from the same circuit schematic (the “BigNet” generalised netlist description).

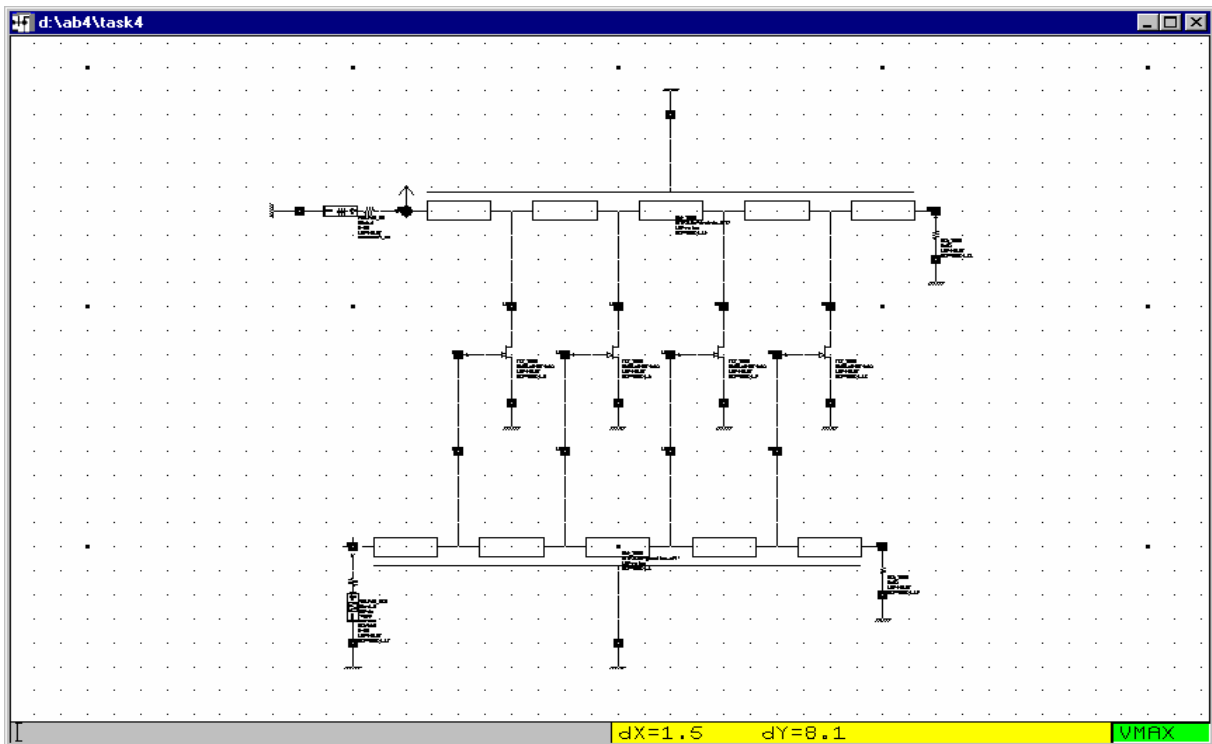

As an example, we will look at a very simple travelling wave amplifier circuit.

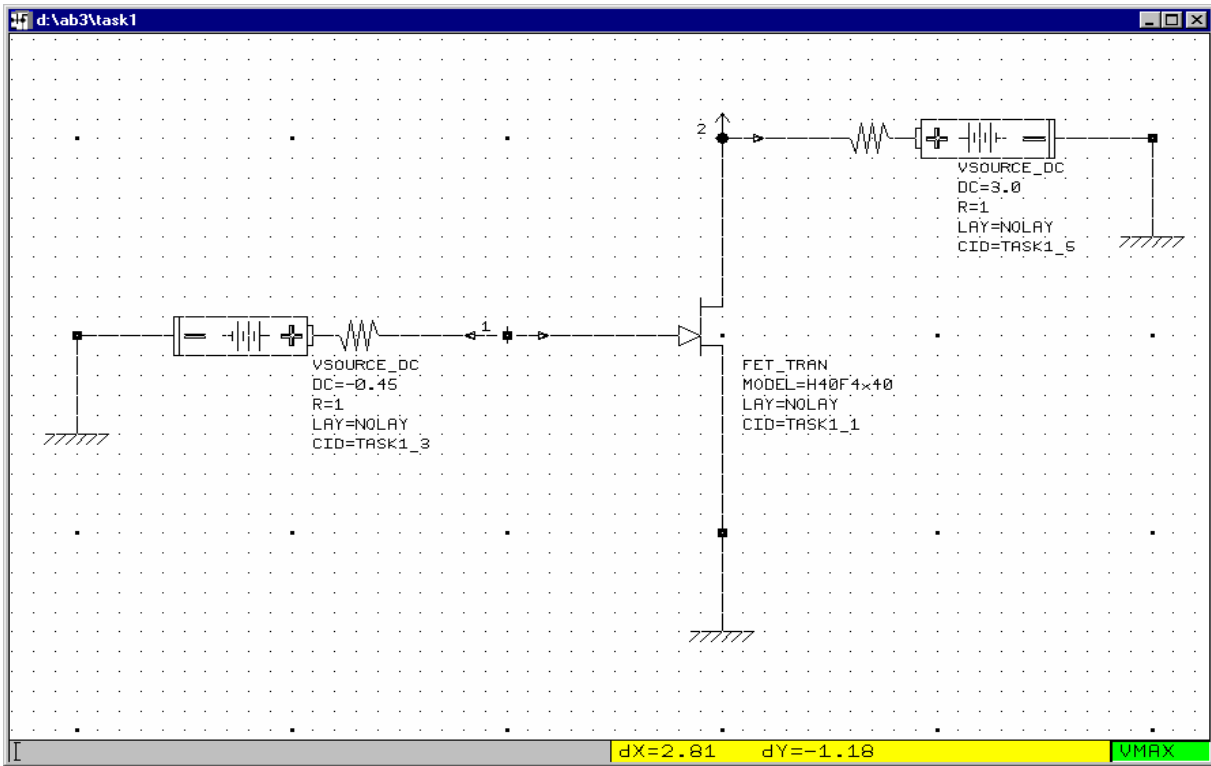

The non-linear circuit description requires the definition of all the biasing and signal source elements.

The screenshot shows the SPICE model parameter list for the H40F4x40 device. The parameters are:

```

H40F4x40 device=EEHEMT level=1 UGW=40e-6 N6F=4 &
Vto=-1.416 Gamma=0.0619 Vgo=-0.537 Vch=0.624 GmMax=0.0738 Vdso=4.0 Vsat=1.79 kapa=0
PePF=3.200 vtso=-10 Vco=-0.433 Mu=0.0064 Vba=0.6026 Vbc=0.5423 Deltgm=0.0542 Alpha=
Rdb=1e9 Cbs=1.6e-13 Gdbm=4.99e-3 Vdsn=1.33 GmMaxAC=0.0069 VtoAC=-1.250 KapaAC=-0.01
GammaAC=0.0216 Kdb=19.5 vtsoAC=-10 DeltgmAC=0.0723 &
Is=4.95e-10 N=1.85 Kbk=1.5e-7 Idsoc=0.095 Vbr=3.5 Nbr=5.0 &
Rs=1.88 Rg=0.68 Rd=3.9 Is=13.45e-12 Lg=24.7e-12 Id=13.83e-12 &
C11o=2.63e-13 C11th=1.10e-14 Vinfl=-0.890 Deltgs=2.8 Deltids=0.784 Lambda=0.0903 &
C12sat=2.34e-14 Cgdsat=2.07e-14 Cdso=38.3e-15 Ris=3.33 Rid=3.33 Tau=0e-12 &
Cpgs=34e-15
CKT
H40F4x40_H401 1 2 0
VSOURCE_VS03 1 0 DC=-0.45 R=1
VSOURCE_VS05 2 0 DC=3.0 R=1
DEFOP TASK1
SWEEP
TIME_S1 lin 0 0 10e-12
  
```

The interface also shows a menu bar with options like FILE, INOUT, EDIT1, EDIT2, VIEW, POINTS, MACROS, SHAPES, LAYERS, SETUP, STYLE, HELP, EDITOR, SCHEM2, and a command window with the text "Replot done." and "NunRows = 71 NunChars = 0."

The schematic capture front end automatically retrieves the model parameter information from the specified data base for the non-linear devices in the circuit

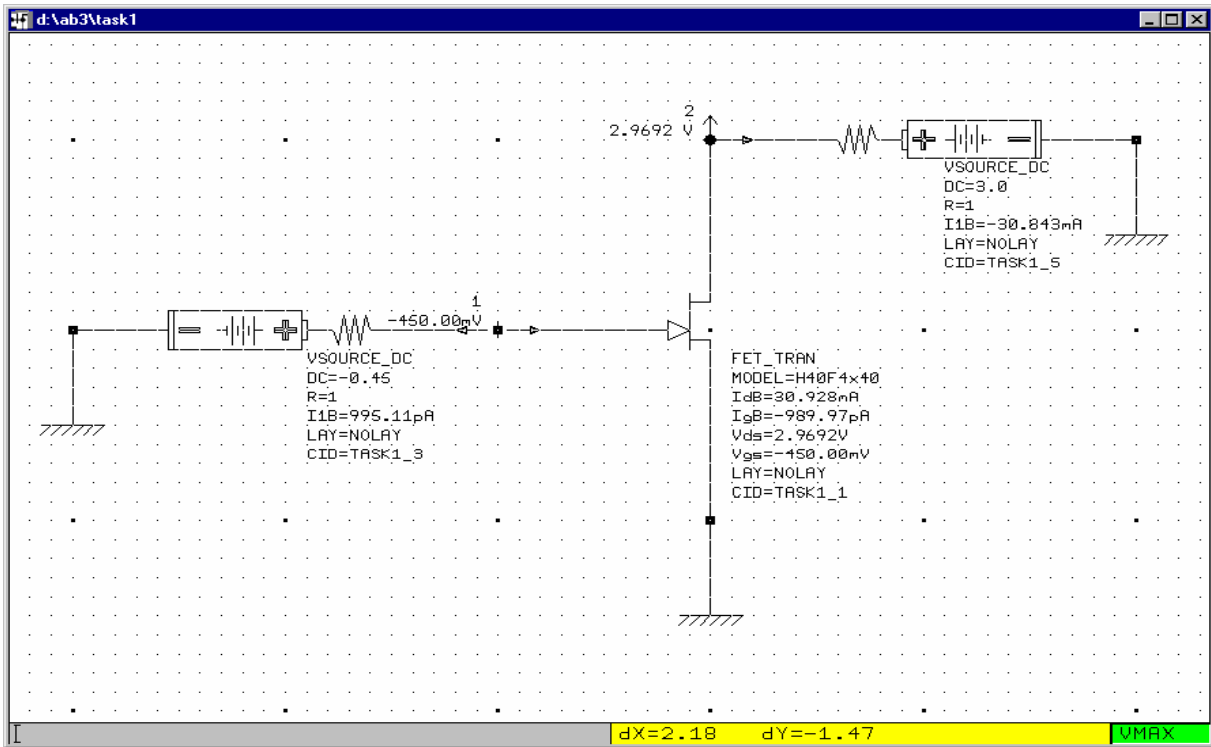

The bias voltages at each node in the circuit can be displayed on the circuit schematic, in addition to the quiescent current into each element, as shown above.

The screenshot shows the software interface with the circuit schematic and a detailed parameter list for the H401 equivalent circuit element. The parameter list includes:

- INTERNAL BIAS Vds=2.828 Vgs=-0.471
- EXTERNAL BIAS Vds=2.969 Vgs=-0.45
- CAP 1 8 C=1.563e-013 ~Cgs
- RES 3 8 R=3.33 ~Ris
- CAP 1 7 C=2.07e-014 ~Cgd
- RES 2 7 R=3.33 ~Rid
- RES 1 3 R=1e+012 ~Rgs
- RES 1 2 R=1e+012 ~Rgd
- RES 2 3 R=218.5 ~Rds
- CAP 2 3 C=3.83e-014 ~Cds
- VCCS 1 2 3 M=0.07548 A=0 R1=0 R2=0 F=0
- VCCS 1 2 3 9 M=0.009328 A=0 R1=0 R2=0 F=0
- VCCS 2 2 3 9 M=0.001001 A=0 R1=0 R2=0 F=0
- CAP 9 3 C=1.6e-013 ~Cbs
- RES 2 9 R=1e+009 ~Rdb
- SRL 4 1 R=0.68 L=2.47e-011 ~Rg/Lg
- SRL 5 2 R=3.9 L=1.383e-011 ~Rd/Ld
- SRL 6 3 R=1.88 L=1.345e-011 ~Rs/Ls
- CAP 1 3 C=3.4e-014 ~parasitic Cgs
- PORT 4 PortNum=1
- PORT 5 PortNum=2

The software interface also shows a menu bar with options like FILE, INOUT, EDIT1, EDIT2, VIEW, POINTS, MACROS, SHAPES, LAYERS, SETUP, STYLE, HELP, COMMON, SCHEM2, and a toolbar with various icons. The status bar at the bottom shows dx=1.28, dy=-0.42, and other system information.

Additionally, the software calculates and can display the values for each of the elements in the linear equivalent circuit model for each non-linear device.

```

Shortcut to cmd
D:\ab4>\wamwork\impulse -i gateline
WaveForm Impulse transformer v1.1 (C) 1998.
Portions (C) Jens Joergen Nielsen.

Reading sNp file gateline.s6p.
Resetting first frequency to zero, forcing real value.
Transforming to causal impulse response.
$11, $12, $13, $14, $15, $16.
$21, $22, $23, $24, $25, $26.
$31, $32, $33, $34, $35, $36.
$41, $42, $43, $44, $45, $46.
$51, $52, $53, $54, $55, $56.
$61, $62, $63, $64, $65, $66.

Writing output file gateline.wfi.
Entries = 1024, interval = 9.775171065e-012.
Done

D:\ab4>

```

Notice that the first entry at $f=1.0E-9$ Hz has been interpreted as the zero frequency (ie. d.c.) entry.

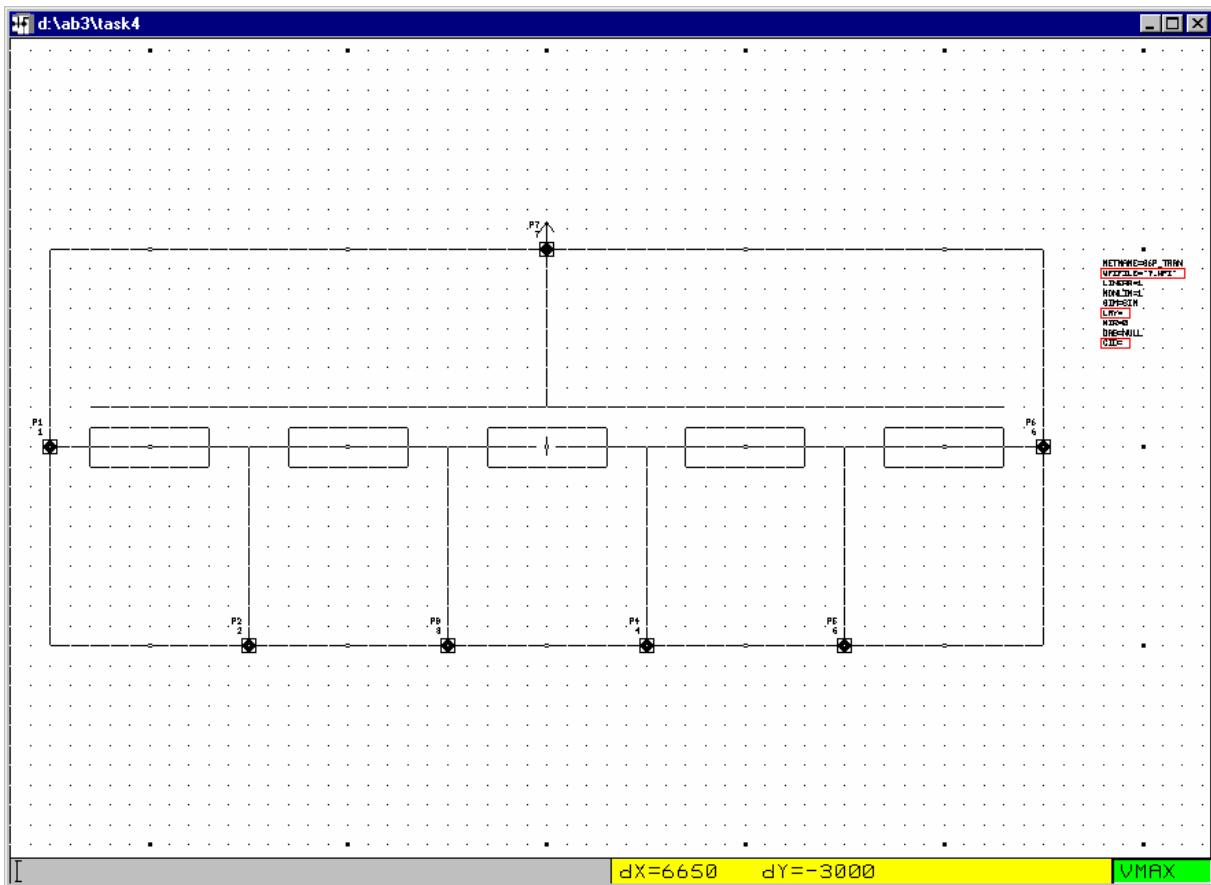

New user defined circuit schematics can be added for new structures, such as the above structure for the gate feed section.

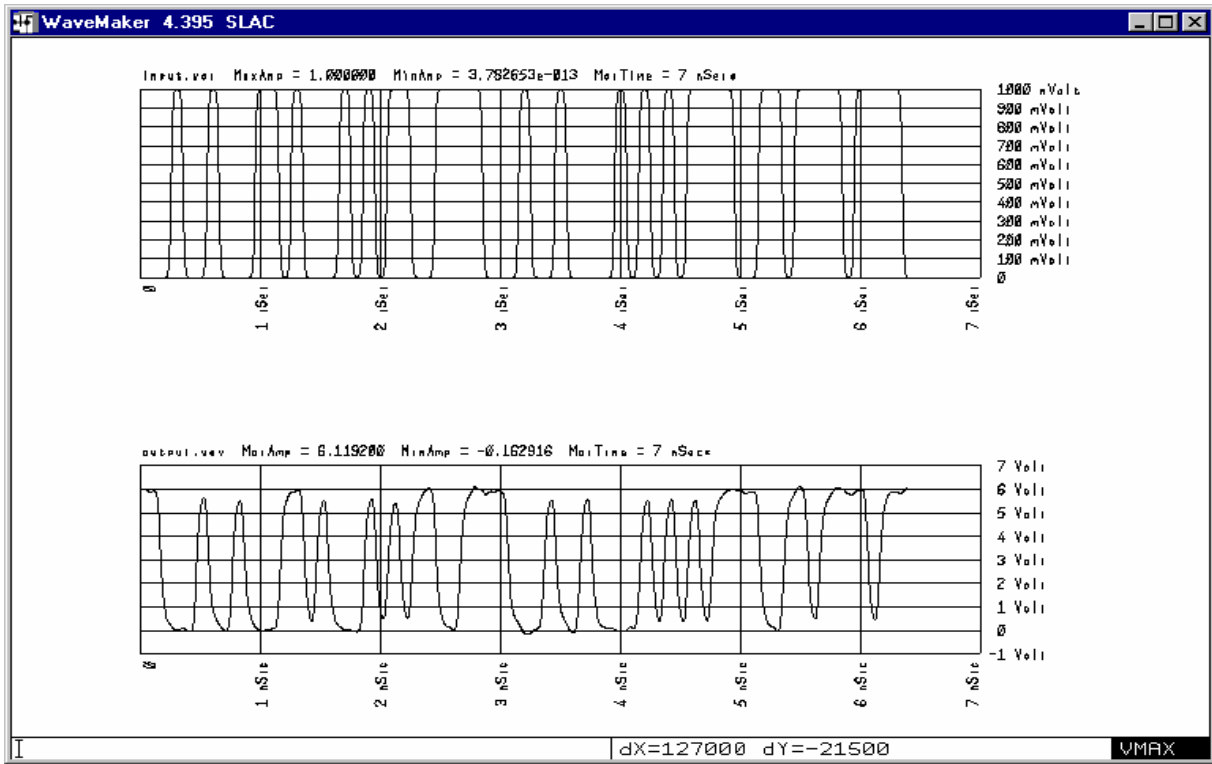

The input and output 10 Gbit/sec NRZ PRBS waveforms.

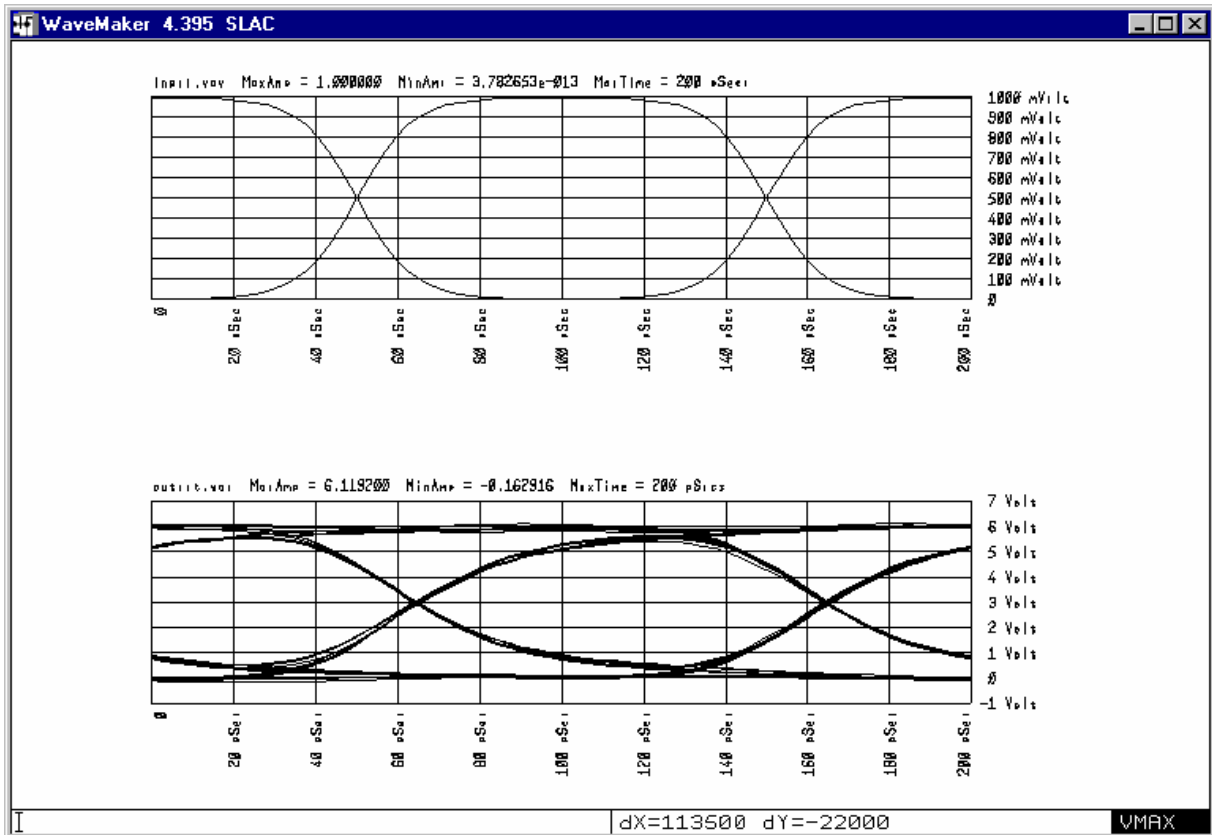

The corresponding “EYE” diagrams for the input and output waveforms.

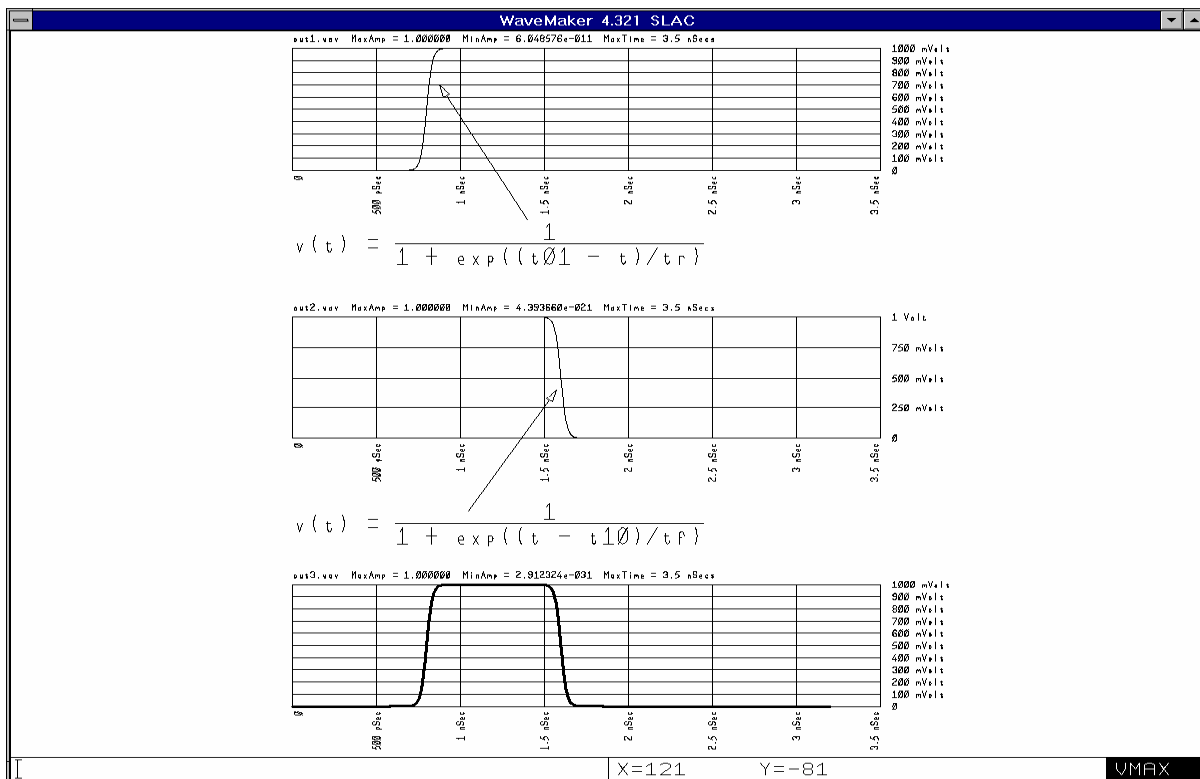

The schematic capture front end supports the generation of realistic waveforms, and the schematic definition of signal pre- and post-processing procedures.

To maintain a balanced presentation, it is important for us to point out the current short and longer term shortcomings associated with the use of this new simulator. Specific features not currently present in waveform include:

- support for Si BJT, GaAs and InP based HBT and Si MOSFET models
- the ability to predict phase noise
- the efficient prediction of the response of a circuit to a slowly varying sine wave (carrier wave envelope simulation).

It is currently a cumbersome procedure to use the time domain simulator to:

- predict the level of the fundamental signal and the harmonics as a function of input signal drive level.
- predict the level of the difference signal in a mixer circuit in which the frequency of the Local Oscillator (LO) signal is close to that of the RF signal.

The accurate extraction of the EEHEMT1 or TOM3 parameters for an arbitrary PHEMT is still problematic, simply because of the scarcity of parameter extractors for these models. This problem applies to both HB and time domain based simulators.

8. Packaging aspects

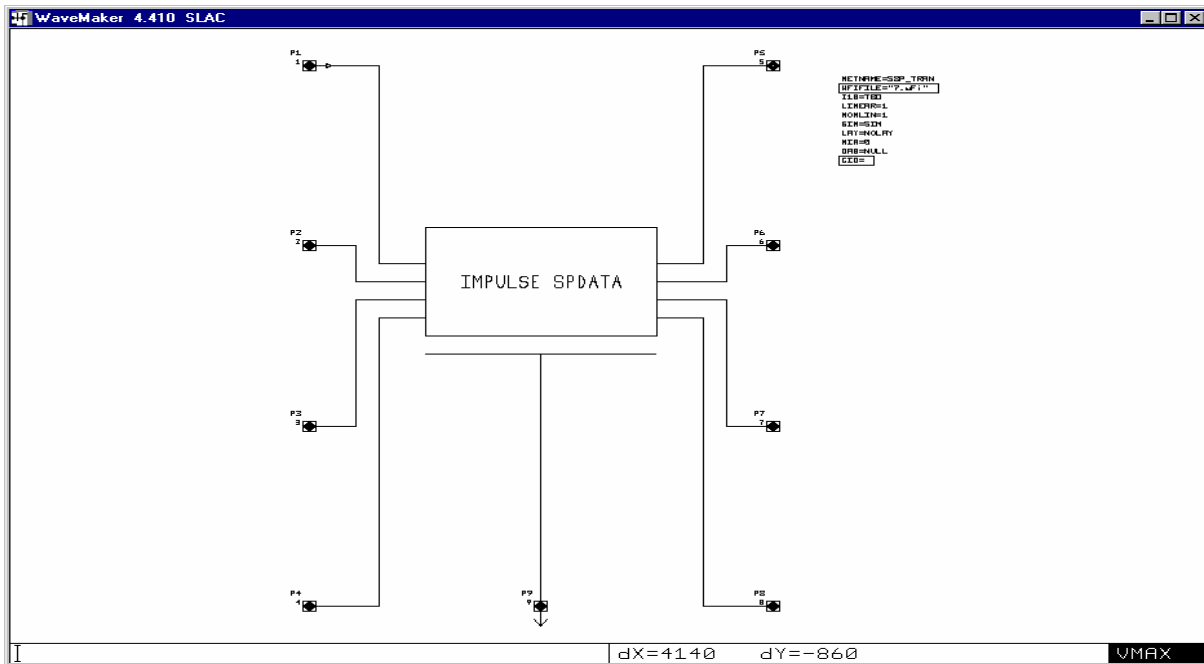

Through the use of this new simulator, in conjunction with an electromagnetics based simulator, we can now accurately predict the effect of:

- coupling between the bond wires between the MMIC and the external world (in the above example, we use an 8 port element to characterise the coupling between 4 bond wires);
- the effect of the dispersive transmission line, including skin effect and other frequency dependent losses, used to connect MMIC terminals;
- the effect of the load impedance, which can be a measured (eg. through the use of a network analyser) and complex response (eg. a microwave antenna)
- the effects of various packaging solutions, where the multi-port S parameter response of the package is predicted through the use of a full 3D (or, if appropriate, a 2.5D) electromagnetic simulator

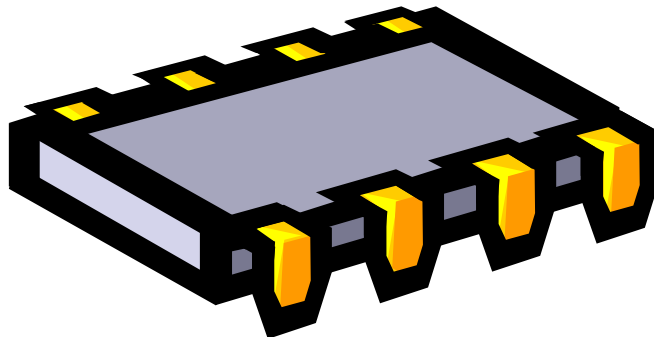

9. Verification of the accuracy of the simulator for linear circuits

For a linear circuit, we can predict the shape of the output and reflected waveforms through the use of the Fast Fourier Transform (FFT). To predict the shape of a waveform from a linear network, knowing the shape of the input waveform (as discussed previously) and the linear network transfer response (S parameters), we use the FFT, convolution and inverse FFT routines as follows:

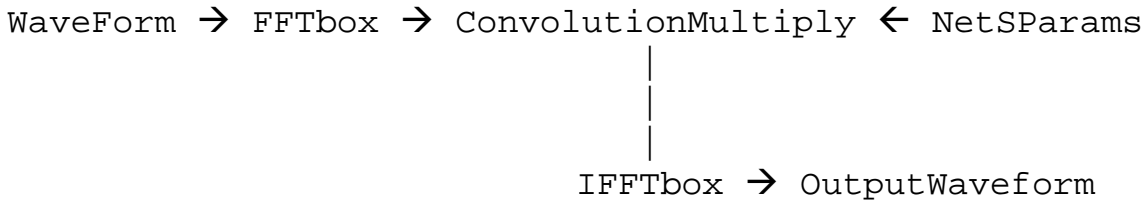

- The S parameters must be saved (transferred) with 17 digits of accuracy.
- The S parameters must be predicted to at least 5 times the bit rate.

The implied assumption is that the linear network sees 50 ohm (or the global characteristic impedance used) real terminations.

10. In conclusion

As a result of a need for a non-linear simulator for use in the accurate simulation of signals in non-linear GaAs ICs operating at 10 Gbit/sec, Barnard Microsystems have developed a new simulator with the following novel features:

- supports import of 1 to 19 port Y and S Parameter data sets
- supports the EEHEMT1, TOM, TOM2, TOM3 and COBRA GaAs MESFET and PHEMT models
- will indicate whether a circuit will unintentionally oscillate without the use of any injected signals

In addition, this new software:

- runs on a Personal Computer under MS Windows 95 / 98 and NT4
- compliments circuit simulators based on the harmonic balance principle

This new software enhances the applicability of time domain based simulation software in the prediction of waveforms in very fast, non-linear, microwave circuits.

11. Some applications of this new software

This new software is intended for **regular and heavy-duty use** in the design of circuits in which the conventional time domain and / or the harmonic balance based simulators are inadequate. Circuits and situations that would greatly benefit for the application of this software have some or all of the following characteristics:

- complex, externally defined voltage and / or current source driving waveforms
- signals large enough to cause strongly non-linear operation of the active devices
- the circuit has an inherently, and strongly non-linear electrical response
- the circuit consists of a mixture of microwave passive elements defined by S parameter data and non-linear active devices
- “transient” phenomenon of interest, such as the start up of oscillations, or the phase shift as a function of time in a pulsed microwave circuit

Specific examples of situations in which the use of this new software is appropriate are as itemised next:

- whether an amplifier or other such circuit will unintentionally oscillate, without requiring the user to inject any “oscillation start up pulses”;
- the behaviour of a VCO with slow and fast variations in the control voltage (no predictions of phase noise);
- the response of a transient overload protection circuit;
- the level of the harmonics generated in a linear amplifier when the amplifier is driven by a high level input signal;
- the interactions (particularly reflected signals) between MMICs connected through the use of transmission lines;
- the operation of ultra wide band (UWB) circuits, as used in UWB RADAR and other systems;
- the phase shift added to a single frequency input signal as a function of time in a pulsed RF circuit (causing “time varying beam skew” when such circuits are used in a phased array RADAR system), resulting from dispersive effects in the PHEMT. For example, the circuit supply voltage may be pulsed ON for 1 uSec, during which time the circuit functions as a power amplifier operating at

around 10 GHz, after which the power is turned OFF for around 2.5 mSec. Such a phase shift will not be indicated through the use of a steady state simulator, such as one based on the use of the Harmonic Balance technique;

the waveforms in a circuit that is operated in a strongly non-linear manner, such as:

- a Step Recovery Diode (SRD) based circuit for impulse generation;
- a Non Linear Transmission Line (NLTL) based circuit;
- a Schottky Barrier Diode (SBD) based signal sampling circuit;

the response of a circuit to complex, base-band, driving signals such as:

- a 10 GBit/sec Non-Return-to-Zero (NRZ) Pseudo Random Bit Sequence (PRBS) as encountered in optical communications modules and circuits;
- a very wide bandwidth noise or pseudo-noise signal (such as WCDMA);
- high bit rate, parallel data bus signals. As an example, in an 8 bit wide, 1 GBit/sec, data bus, the complex electrical characteristics of the 8 coupled microstrip data tracks could be defined through the use of an electromagnetic simulator as a 16 port S parameter data set;

the response of a circuit:

- in an electrically noisy environment;
- to signals picked up from a nearby, high power, RADAR system;
- to impulses picked up from a nearby UWB RADAR system;
- to signals picked up from a nearby, high power, electronic warfare system;
- to an electromagnetic pulse (EMP) from a nuclear explosion, or other such powerful source.

The Impulse software on its own can be used to visualise the response of a passive element or circuit section in the time domain. If the visualisation indicates that part of the response appears to occur before time $t=0$, then the “non-causal” or “unphysical” response needs to be corrected before the data is used in any simulation. The cause of such an “unphysical” response could result from the over de-embedding of measurement data, or inaccuracies in the closed form mathematical equations used to predict the real and imaginary parts of the circuit response as a function of frequency.

Outline “impulse” Software Specifications

S or Y parameters defined in a data file using the well-known Touchstone ® format.

First frequency point need not be zero: if it is less than 1.0% of the second frequency, the software will assume this to be the zero frequency entry.

The interval between all the adjacent frequency points (with the first point assumed to be at zero Hz) must be the same, and must equal the value of the second frequency point.

Data for structures with from one to 19 ports may be used.

Any of the S or Y parameters may exhibit gain (ie. $S_{mn} > 1.0$).

Outline “waveform” Software Specifications

Elements supported include:

- resistor
- capacitor
- inductor
- Voltage Controlled Voltage Source with optional use of delay
- Voltage Controlled Current Source with optional use of delay

- d.c. voltage and current sources
- sine wave voltage and current sources
- external waveform controlled voltage and current sources

- Import of 1 to 19 port S or Y parameter data blocks

- Standard SPICE compatible diode model

- TOM, TOM2, TOM3, Cobra and EEHEMT1 GaAs FET models

Software will calculate equivalent circuit model (including noise sources) values for each active device at quiescent bias point.

Software will display bias voltages and currents on the circuit schematic.

Software will generate a data base containing the predicted voltages at each node in the circuit.

Software can be used to superimpose bias plane trajectory on FET IV characteristics.