

Waveform Simulator Reference

Michael R S Taylor and Dr Joseph A Barnard

© Michael R S Taylor and BML 1998-9

7th April 1999

waveform.doc

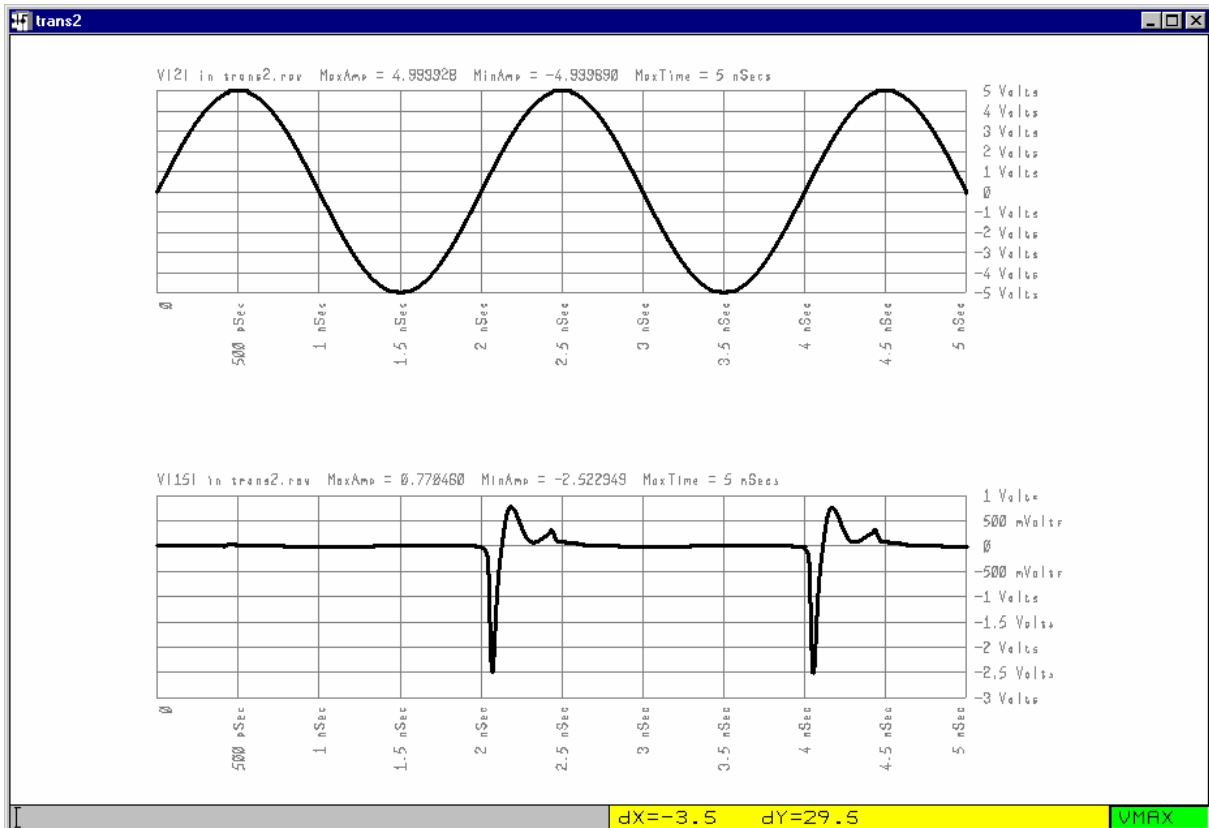

Waveform is a unique time domain transient simulator that supports accurate non-linear GaAs FET models and the import of both S Parameter data and complex waveforms defined in the time domain. Such a simulator has applicability in the simulation of fast microwave and optoelectronic circuits.

Contents

1. Introduction
2. Command line parameters
3. Netlist file format
4. General
5. Assignment to parameters
6. Parameter names
7. Short circuits
8. Netlist blocks: the DIM block
9. Netlist blocks: the VAR block
10. Netlist blocks: the MODEL block
11. Netlist blocks: the CKT block
12. Netlist blocks: the SWEEP block
13. Netlist blocks: the OUT block
14. Output Files
15. Example WaveForm WFout.txt file:
16. Example WaveForm rawspice.raw file:
17. Schematic capture
18. Impulse: the frequency domain to time domain network response converter.
19. Use of “include” files
20. Scaling of diode areas and FET gate widths
21. WaveForm Devices

1. Introduction

WaveForm is a nonlinear, time domain simulator that operates on a circuit defined in a netlist data file to produce two output data files containing the predicted circuit response in two text formats. The executable is a “character mode” executable that runs on a PC under Microsoft Windows NT version 4, or higher. To get reasonable run times, it is suggested that the simulator be run on a PC with a clock speed of 450 MHz or higher, with the CPU having a cache size of at least 512 Kbytes. The RAM size should be 64 Kbytes, although the software does not require excessive amounts of RAM, since most of the computations are performed in the cache memory.

The solution algorithm is based on the relaxation method, as opposed to the more commonly used approach, as used in SPICE, in which the inverse of the nodal admittance matrix is repeatedly calculated. This approach has been selected in order to provide a very stable solution technique that can both achieve convergence and maintain accuracy of the solution even for a circuit with a nodal admittance matrix that is close to being singular. In other words, for some circuits, a time domain simulation based on a repetitive solution of the inverse NAM would result in either a lack of convergence to a solution, or significant loss in accuracy, whereas the approach we have adopted reflects our priorities of simulator robustness first, accuracy second and simulator speed third.

The syntax of the netlist is derived from a combination of the standard SPICE and Touchstone™ netlists. One of the output data formats is in the standard SPICE .raw format, while the other output is in a form that can be accessed through the use of the Microsoft Excel database program.

The unique points of this simulator are:

- support for advanced GaAs FET models;

- support for the inclusion and use of processed S Parameter data;
- support for the import of complex waveforms.

The netlist can be created or modified through the use of a text editor, prior to the use of the simulator. A visually more helpful way in which to create the netlist is through the use of the WaveMaker schematic capture capability. For ease of parameter definition, some of the element syntax has been changed to reduce to a minimum the frequency with which the user needs to consult the notes on the simulator. The ExportNet command in WaveMaker will translate the schematic parameter text to conform to the syntax requirements of the WaveForm simulator.

Prior to use of any S parameter data in the time domain simulation, you will need to use the Impulse character mode executable to convert the frequency domain circuit response data to its equivalent time domain form. Impulse can currently manage S parameter data sets up to 9 ports.

Once a simulation has been successfully performed, you can use WaveMaker or some other appropriate software to visualise the contents of the standard output.raw waveform data file.

2. Command line parameters

WaveForm will accept up to seven command line parameters, five of which control the output format and user interaction, the other two of which are input and output file names.

The keyword **noprogress** will disable the printing of progress information to screen during the solution.

The keyword **batch** will disable any interaction with the user at the end of the run.

By default, WaveForm output files will contain node voltages and device currents for the top level circuit only. The command line option **allevs** will cause node voltages and device currents for all subcircuits to be produced as well. By default, WaveForm does not produce output for internal nodes and currents for the more complex devices, such as FETs. The command line options **allnodes** and **allcurrents** will override this behaviour.

Of the remaining parameters the first is interpreted as the name of the input file, the second as the base name for the output files. WaveForm will attempt to open the file with the name as given, and then using .cir and .ckt extensions if it doesn't find it, in that order.

The output files have the extensions .txt and .raw added for the two output files. If no output file name is specified the output files will be called simout.txt and rawspice.raw. If no input file name is specified WaveForm will try to open a file called circuit.ckt. An example of a WaveForm command line is as follows:

```
WaveForm circuit.cir allnodes batch
```

The options are:

Name	Short name
NoProgress	Nopr
Batch	Bat
AllLevels	Alll

AllNodes	Alln
AllCurrents	Allc
ac	ac

The “ac” keyword after the name of the circuit file instructs the software to create a file called CircuitName.inc, where CircuitName is the CircuitName.cir of the circuit. This file contains a set of small signal circuits, one for each FET in the circuit, with the element parameters appropriate to the FET at the calculated d.c. bias point. Each FET has an equivalent circuit representation that is as follows:

```

BEGIN h4022 TYPE=CIRCUIT
DATA Metric=YES
DATA AutoLAY=NO
! INTERNAL BIAS Vds=0.9899 Vgs=-0.01644
! EXTERNAL BIAS Vds=1.184 Vgs=0
CAP 1 8 C=1.881e-14 !Cgs
RES 3 8 R=22.7 !Ris
CAP 1 7 C=3.96e-15 !Cgd
RES 2 7 R=22.7 !Rid
RES 1 3 R=1.088e+09 !Rgs
RES 1 2 R=1e+12 !Rgd
RES 2 3 R=1703 !Rds
CAP 2 3 C=1.325e-14 !Cds
VCCS 1 2 3 3 M=0.0106 A=0 R1=0 R2=0 F=0 T=0 !Gm(dc)
VCCS 1 2 3 9 M=0.001165 A=0 R1=0 R2=0 F=0 T=0 !Gm(ac)
VCCS 2 2 3 9 M=5.857e-05 A=0 R1=0 R2=0 F=0 T=0 !Yds(ac)
CAP 9 3 C=2.7e-14 !Cbs
RES 2 9 R=6e+09 !Rdb
SRL 4 1 R=2.138 L=2.089e-11 !Rg/Lg
SRL 5 2 R=23.14 L=1.836e-11 !Rd/Ld
SRL 6 3 R=10.29 L=4.5e-12 !Rs/Ls
CAP 1 3 C=1.38e-14 !parasitic Cgs
PORT 4 PortNum=1
PORT 5 PortNum=2
PORT 6 PortNum=3
END h4022

```

The linear equivalent is different for each type of device model. The above example applies to the EEHEMT1 GaAs FET model.

3. Netlist file format

An example of the Waveform netlist description is as follows:

```
! test file 1 for WaveForm
! passive fet mixer.

var
sysz0 = 50

model
monofet device=tomfet level=1 cds=18.32125f cgd = 17.0095f &
cgs=37.0095f n=1.94027 is=10.372n vbi=0.839117 delta=6.20952 &
beta=0.0476935 vto=-0.504142 gamma=0.0176 q=1.89791 rg=4.1 &
rs=3.1 rd=4.1

ckt
vsource_vlo 5 0 sin=(0 1.414 14g 0 0) r=sysz0
vsource_vrf 1 0 sin=(0 0.33 12.5g 0 0) r=sysz0
res_rifterm 6 0 r=sysz0
cap_crfmatch 1 2 c=35f
cap_clomatch 4 5 c=140f
cap_ciffilter 6 0 c=1n
ind_lrfmatch 2 0 l=450p r=1
ind_llomatch 5 0 l=200p r=1
ind_liffilter 4 6 l=1n r=1
monofet_fet1 4 2 0
DEFOP TEST

sweep
time_s1 lin 0 22e-9 5e-12
```

4. General

The netlist syntax is similar to Touchstone, with extensions. It is not case sensitive. Line endings may be Mac or PC style. Anything following a “!” character is a comment. The continuation lines are denoted by an “&” character as the last non-comment character on the preceding line.

Comments are removed before continued lines are concatenated, so a comment can immediately follow an "&" character. An "&" character following a "!" comment character will be ignored. Single lines may be up to 508 characters long, continued lines may be up to 4092 characters long.

5. Assignment to parameters

All assignments may be made using the "=", "^" or "#" character. A white space between the parameter name, the "=", "^" or "#" assignment operator and the value will be ignored. Assignments of vector (multiple) values must be enclosed in brackets, for example:

```
pwl = (0 0 1 0.5 2 0)
```

Values in vectors and assignments may be separated by any white space (space, tab, newline) or commas. String values must be enclosed in quotation marks. For example:

```
windowfunction=hanning  
pwlfile="25psonce.pwl"
```

Boolean values can be entered using the strings true and false with or without quotation marks. Alternatively, giving just the name, with no = after it, of a parameter which takes a boolean value will set it to true.

Unlike SPICE, all non-boolean assignments need an "=", "#" or "^" character between the parameter name and the parameter value. In other words:

```
sin(-0.4 1 15e9 0 0)
```

is not allowed, it has to be:

```
sin = (-0.4 1 15e9 0 0)
```

Variables are not allowed in vector values. In vector assignments, values can be read in from file if the keyword file:fileName is used. This must appear at the beginning of the vector, with no spaces. Values in the file will be read in one after the other and can be separated by any combination of white space and commas. There is no predefined limit on the number of values in a vector eg:

```
pwlfile="sigin1.wav"
```

Currently, the file name in this case will be converted to lower case.

6. Parameter names

Almost all names of parameters and devices may be shortened to the minimum unambiguous value, or anything between the full name and the shortest. For example, independent voltage source (vsource) may be referred to as:

```
Vs  
Vso  
Vsou  
Vsour  
Vsourc  
vsource
```

and the associated parameter pwl as:

```
p  
pw  
pwl
```

This does not apply to names (identifiers) assigned in the netlist file, ie. of variables or models or (sub)circuits.

7. Short circuits

DC or AC short circuits are not allowed within any element, and so all voltage sources, capacitors, and inductors have a compulsory series resistance element, which has no default value. The minimum allowed value for this resistance is 0.1Ω , but using larger values (such as 10.0 ohms) should reduce the solution time.

8. Netlist blocks: the DIM block

The following dimensions are supported:

name	supported values	default value
freq	hz, khz, mhz, ghz	ghz
res	oh, koh, moh	oh
cond	usie, msie, sie, ksie	sie
cap	ff, pf, nf, uf, mf, f	pf
ind	fh, ph, nh, mh, h	ph
lng	nm, um, mm, cm, m, uin, mil, in	um
ang	deg, rad	deg
time	ps, ns, us, ms, s	s

current	pa, na, ua, ma, a	ma
voltage	pv, nv, uv, mv, v	v
temp	C, K, F	C

The single word “spice” on a line on it’s own, enables the use of SPICE style modifiers for numeric values, and resets all dimensions to base (not default) values. The SPICE modifiers are:

name	SI name	scale factor
t	tera	10^{12}
g	giga	10^9
meg	mega	10^6
k	kilo	10^3
m	milli	10^{-3}
u	micro	10^{-6}
n	nano	10^{-9}
p	pico	10^{-12}
f	femto	10^{-15}
a	atto	10^{-18}
thou	(imperial)	$25.4 \cdot 10^{-6}$
mil	(imperial)	$25.4 \cdot 10^{-6}$

Any later dimension assignment will disable the SPICE style modifiers, but leave the base dimensions. The base value for angles after the spice command is degrees, and for temperature degrees Centigrade. Whilst SPICE style modifiers are enabled, any characters after the SPICE dimension name are ignored, and the actual units are not important (so that the mil specifier can be used for temperature, for example, even though this would be unwise)

Derived units are not affected by DIM settings (ie. mobility in m^2/Vs would not be affected by settings for voltage, length, or time).

9. Netlist blocks: the VAR block

The format used here is best illustrated by examples:

```
C1=1.5p
R5=50
```

Assigns the value of 1.5e-15 to the variable called C1, and assigns the value of 50 to the variable called R5.

10. Netlist blocks: the MODEL block

For WaveForm, any device may be defined as a model, using the same parameters as for instances in the CKT block, later definitions in the CKT block will override the ones set for the model. Scaling of models is implemented, in a device specific manner. The format is:

```
modelname device = devicename parameters
```

For example, to create a model of a 50 ohm resistance, we would specify:

```
VENKEL50 dev=res r=50
```

11. Netlist blocks: the CKT block

Circuits are specified as a combination of devices, models, and subcircuits. Any item may be given an optional identifying name by following the device, model, or subcircuit name with an underscore and the name. These identifying names are used when creating names for internal nodes in some devices and for identifying currents in devices. Identifying names must start with an alphabetical character and may contain the characters ‘abcdefghijklmnopqrstuvwxyz0123456789#@!£\$%&*+ -=’ also the block names and device names are not allowed as names nor the word “main”. Identifying names do not need to be unique, although it is easier to understand the output if they are, nor are they case sensitive. The general format is:

```
devicename(_optional identifier name) node node parameters
```

Sub-circuits are defined by a defNp statement as in Touchstone, and are then included by name in other circuits. The name for a sub-circuit is useful in more complex circuits in identifying which instance of the sub-circuit a node or device occurs. Sub-circuits may have up to 9 ports.

A circuit without any ports should still have a DEFOP keyword at the end of the listing of the elements in the circuit section:

```

tline_line1 1 0 2 0 z0=50 delay#1e-10
def2p 1 2 line

vsource_source1 1 0 pwl=(0 0 99p 0 100p 1 101p 0 1n 0) r=0.01
VENKEL_r1 1 2 r=sysz0
line_aline 2 3
res_r2 3 0 r=100
cap_c1 3 0 c=1e-12
DEF0P MAIN

```

Clearly, such an unclosed circuit cannot be used as a subcircuit in another circuit, as it has no specified ports. The N in defNp can be 0, which produces a circuit which cannot be used as a subcircuit, but enables a name to be given to a circuit with no ports, which can be used as a top level circuit for analysis.

12. Netlist blocks: the SWEEP block

Analyses are defined in the SWEEP block, there are 3 primary sweep types, time, frequency, and variable. Sweeps may be either linear or logarithmic (time sweeps must be linear) specified by a keyword (lin or log) before the sweep parameters. The sweep parameters are variable name for a variable sweep, followed by start, stop, and increment for linear sweeps, or start, stop, number of points for a log sweep. WAVEFORM analysis options are optionally specified after the sweep parameters, so each sweep can have separate options. The options must be preceded by the options keyword. The sweeps may be given identifying names which are used in the OUT block eg:

```

time_s1 lin 0 1e-9 1e-12 options chargetol=1e-20
variable_s2 lin sysz0 1 100 1

```

Note:

1. Global temperature effects are not yet implemented, but temperature can be set for individual devices.
2. The SWEEP and OUT blocks do not accept SPICE style dimension specifiers, and do not use the TOUCHSTONE™ dimensions set in the DIM block.

The options available for the solver are:

name	short name	description	default value
chargetol	c	Absolute charge tolerance in Coulombs	1.6e-20
itol	ito	Absolute current tolerance for DC solution [Amps]	1e-9
minvol	minv	Minimum voltage (voltage treated as zero)	1e-9
absvtol	a	Absolute voltage tolerance for convergence	1e-8
relvtol	r	Relative voltage tolerance for convergence	1e-8
orfactor	or	Over-relaxation factor (in range 1.0 to 2.0, smaller is slower but more stable)	1.85

iterlimit	it	Limiting number of iterations at a timepoint	3000
iiterlimit	ii	Limiting number of DC iterations	60000
minstep	mins	Limiting value of timestep	1e-18
intmethod	in	Integration method: 0 = rectangular 1 = trapezoidal	0

Explanation of settable options.

A brief explanation of the inner workings of waveform is necessary to understand the settings of these parameters. Waveform works by altering the voltage on each node in the circuit in order to minimise the total charge on the node in a process called relaxation by making the voltage equal to that which gives zero charge for that particular node. It does this for each node in turn, and one iteration consists of a single alteration for all of the nodes. This operation can be speeded up by changing the voltage more than that needed to zero the charge, a process called over-relaxation. Use of this approach can lead to a considerably faster convergence than simple relaxation because of the interactions between nodes.

Unfortunately, over-relaxation can be unstable because of this excessive voltage change. The optimum factor by which to over-relax is different for each node in each circuit. Waveform can identify some nodes which need a very low over-relaxation factor, and apply the low factor only to those nodes. For the other nodes, the same relaxation value is used.

The default factor is shown above. If waveform finds that the solution is unstable, it will automatically reduce this value. Occasionally the value is not quite large enough to cause instability, but just large enough to slow down convergence significantly. Distinguishing this case from that of a node which simply converges slowly is difficult, and here the limiting number of iterations at a time point is used. If the number of iterations reaches a predefined value, waveform either reduces the over-relaxation factor, or reduces the time step, in an attempt to reach convergence. The over-relaxation factor is never increased, so the value at the end of the analysis is the lowest value. This final value is usually a good value for the analysis of the particular circuit. In order to be able to use this information, waveform prints out the final value of the over-relaxation at the end of the analysis.

It is intended that this process should be further automated in later releases, and fewer settings of global options will be necessary. For the DC analysis, a very large number of iterations may be required, and a separate limiting number of iterations can be defined. If there is no DC convergence within iiterlimit iterations, waveform will report that it is not able to find a d.c. solution.

In order to establish that the solution has converged at a particular time-point, a number of checks must be satisfied:

- the total charge on the node must be less than `chargetol`, or DC current must be less than `itol`;
- the voltage change between iterations must either be less in absolute terms than `absvtol` or less in relative terms (as a fraction of the node voltage) than `relvtol`.

As a general rule, the error in the node voltages will be of the order of 10 times the larger of absvtol, or relvtol times the node voltage. The global options are set in the SWEEP block as follows:

```
SWEEP
time_s1 LIN 0 1e-9 1e-12 options orfactor=1.0 absvtol = 1e-10
```

13. Netlist blocks: the OUT block

The OUT block is used to specify a circuit, the analysis to be used, and the output required. It is optional. The format is:

```
CircuitName sweep
```

The output type may be one of the standard Touchstone outputs or VALL or VPORTS for time based sweeps.

The sweep may be specified using a sweep name defined in the SWEEP block, or a sweep type (time, frequency, or variable), in which case there must not be more than one sweep of that type specified.

If there is no OUT block, and only one sweep specified in the SWEEP block, then WaveForm will apply that sweep to the last circuit specified in the CKT block.

14. Output Files

WaveForm produces two output files containing the same information in different formats. The filenames depend on the command line parameters as explained above. The file with the .txt extension is a tab-delimited column format with the column titles in the first row, suitable for reading into most spreadsheets and graphing programs. The file with the .raw extension is in SPICE rawspice format.

15. Example WaveForm WFout.txt file:

time	V(102)	V(2)	V(1)	V(3)	V(103)	I(vsig2)
0	1.5	1.5	5.855622	1.556086	1.618962	3.40E-10
3.13E-12	1.5	1.5	5.855622	1.556086	1.618962	-4.88E-10
6.25E-12	1.5	1.5	5.855622	1.556086	1.618962	-2.15E-09
9.38E-12	1.5	1.5	5.855622	1.556086	1.618962	-5.03E-09
1.25E-11	1.500001	1.499999	5.855622	1.556086	1.618962	-1.08E-08

The actual output file will have greater numerical precision than the example.

16. Example WaveForm rawspice.raw file:

```
Title: task1
```

```

Date: Wed Dec 23 06:15:28 1998
Plotname: default analysis
Flags: real
No. Variables: 8
No. Points: 321
Command: WaveForm Copyright 1997, 1998.
Variables:
    0      time      time
    1      V(102)    voltage
    2      V(2)      voltage
    3      V(1)      voltage
    4      V(3)      voltage
    5      V(103)    voltage
    6      I(vsig2)   current
    7      I(vsig1)   current
    8      I(vbias)   current

```

```

Values:
0      0.000000000000000000e+000
      1.50000010168417110e+000
      1.49999993233815010e+000
      5.85562209280311310e+000
      1.55608605126866230e+000
      1.61896187993132500e+000
      3.40222592321026710e-010
      3.40223831329922160e-010
      -1.44377907196886920e+000
1      3.125000000000000010e-012
      1.50000014382734870e+000
      1.49999989025498890e+000
      5.85562209248659740e+000
      1.55608565904902970e+000
      1.61896213923401940e+000
      -4.88345075488894100e-010
      1.16999182786514660e-009
      -1.44377907513402630e+000
2      6.250000000000000020e-012
      1.50000022702814010e+000
      1.49999980710341130e+000
      5.85562209239017760e+000
      1.55608558171159420e+000
      1.61896219444106440e+000
      -2.14531957976049650e-009
      2.82795060702056860e-009
      -1.44377907609822390e+000

```

17. Schematic capture

Note that for convenience of the users of the Waveform simulator, the schematic capture element syntax is more detailed than that specified for the simulator itself. For instance, for the independent SINE voltage source, the schematic capture parameter display is as follows:

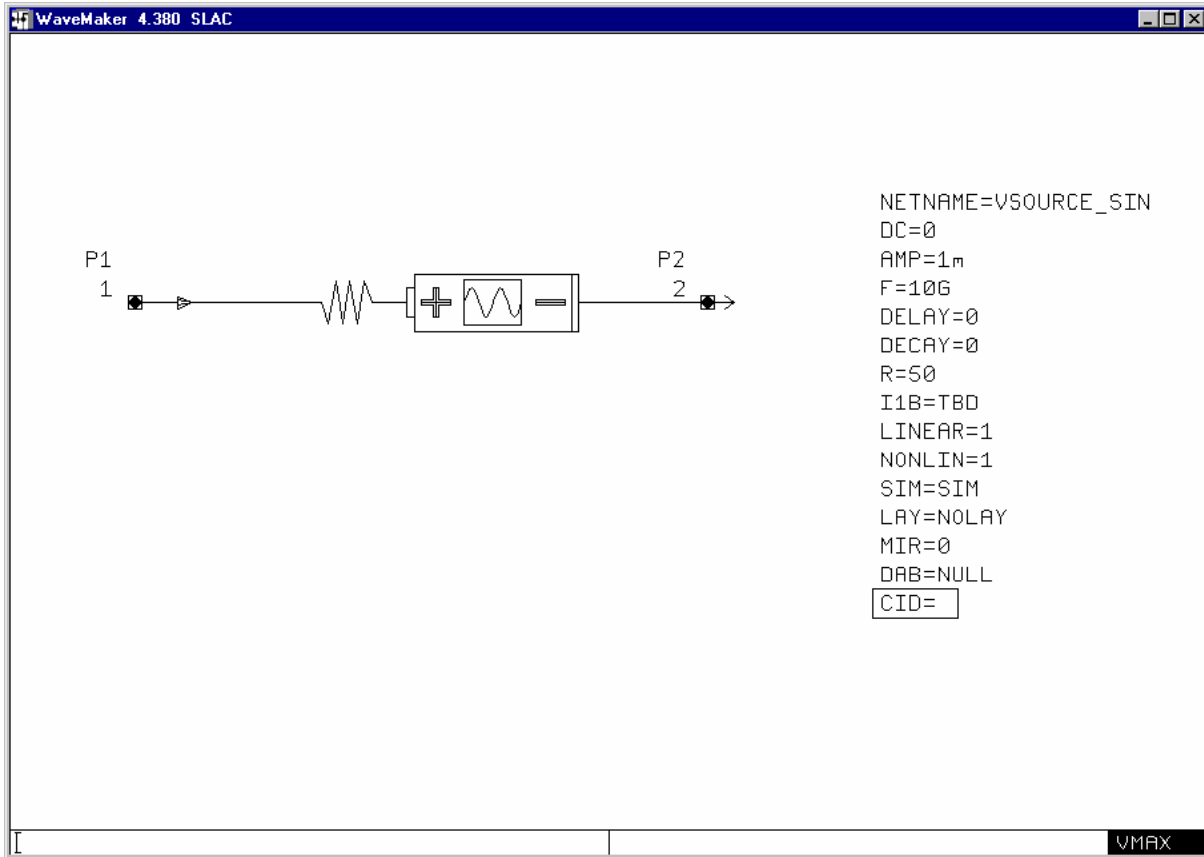

whereas the entry in the actual netlist as used by the simulator is:

```
VSOURCE_VSO5 1 2 SIN=(0 1m 10G 0 0) R=50
```

Usually the user is not presented with all the parameters as shown above. In fact, the above is the maximum display of all the possible parameters, simply for reference purposes.

18. Impulse: the frequency domain to time domain network response converter.

The Impulse utility is used to convert the frequency domain S parameter data to its equivalent time domain network impulse response representation. This utility is a stand alone character mode executable that can be used from within WaveMaker, or on its own. A typical command line operation of this utility is:

```
impulse examlin.s2p
```

The software deduces that the data is 2 port data from the .s2p file name extension. The impulse response data will be stored in a file called examlin.wfi.

Impulse is a frequency response-to-impulse response transformer for use with WaveForm. It accepts input in S-parameter format, Touchstone style .sNp files with N ranging from 1 to 9. Impulse applies a Hilbert transform to the data to generate a modified frequency response which is always causal. This is necessary to avoid an impulse response with non-zero values for negative time, which the WaveForm time-domain simulator cannot implement.

Impulse accepts the following command line options:

```
filename      input file name,  
              with or without extension,  
              compulsory.
```

```
-o filename    output file name,  
              optional.
```

```
-mp           circuit is minimum phase,  
              optional.
```

```
-n NumPorts   number of ports = NumPorts in data file,  
              (overrides .sNp extension info),  
              optional.
```

```
-nc           do not transform for causality,  
              optional.
```

```
-nr           do not add resistance to each port,  
              optional.
```

```
-pc           passive circuit,  
              force all magnitudes <= 1,  
              optional.
```

```
-r Rvalue     resistance = Rvalue to add to each port,  
              optional.
```

```
-y           output Y-parameters,  
              optional.
```

The default command line of impulse -i filename should be suitable for most purposes, it produces a text file with a .wfi extension containing all the information required by the WaveForm s1p...s9p elements, using the wfile="filename" parameter. Impulse assumes that the number of ports in the file is equal to the N in the .sNp file extension. If this is not the case, the -n option must be used to specify the number of ports.

WaveForm requires the impulse response to have some loss, especially at DC in order for convergence to be fast enough. Impulse therefore by default adds series resistances (0.1 ohm default value) to all the ports. The value of the resistance can be changed through the use of the -r option. The resistance can also be turned off through the use of the -nr option. Values of resistance less than 0.01 ohm will probably not allow convergence, or the convergence will be relatively slow, unless the circuit has a reasonable intrinsic DC loss. The issue of adding series resistance at ports is particularly important when data from a simulator based on electromagnetic theory is used. Often, when such a simulator is used, the losses in the dielectric (tangential loss ratio) and other distributed losses are set to zero in order to speed up the simulation. Such an action results in a very low loss as predicted at d.c. The addition of the series resistances only affects the d.c. setting.

In order for the impulse response to be accurate, it is usually necessary to use an extended frequency response to get an accurate impulse response. There are two main reasons for this. Firstly, the Fourier transform used to generate the impulse response implicitly wraps the frequency response about the upper frequency in the file. This gives rise to an unrealistic high frequency response which can affect the time domain solver, and also usually gives rise to an unrealistic phase response, which leads to a non-causal impulse response (impulse response starts before time zero) and hence incorrect time-domain modelling. Secondly, the transform used by Impulse to enforce causality and overcome this problem, can alter the frequency response at some frequencies well below the upper frequency, especially if the magnitude and phase are large at that frequency. It is recommended that one extends the frequency response if possible to a frequency at which the magnitude of the S-parameters are small, and their phase close to zero. If that is not possible, the best results will be achieved by extending the frequency response to a factor of 4, or more, above the highest frequency of interest. If using measurements or electromagnetic simulation to produce the S-parameters, it is possible to use a larger frequency step at higher frequencies if the resulting file is read into WaveMaker and output at a uniform frequency spacing

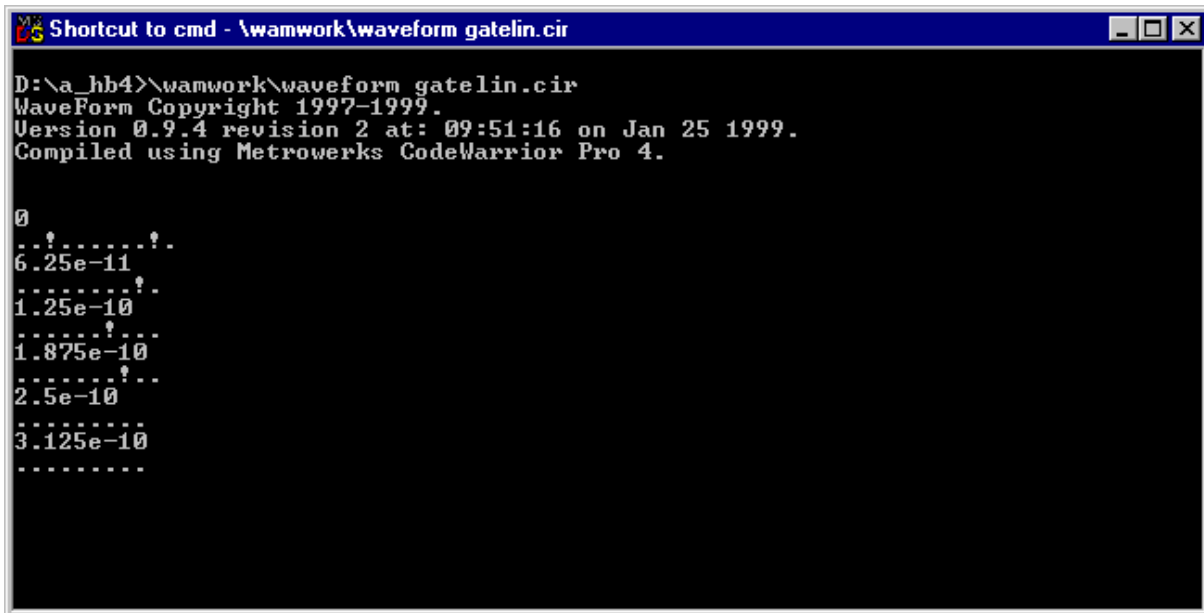

```
Shortcut to cmd - \wamwork\waveform gatelin.cir
D:\a_hb4>\wamwork\waveform gatelin.cir
WaveForm Copyright 1997-1999.
Version 0.9.4 revision 2 at: 09:51:16 on Jan 25 1999.
Compiled using Metrowerks CodeWarrior Pro 4.

0
  .? .....?
6.25e-11
  .? .....?
1.25e-10
  .? .....?
1.875e-10
  .? .....?
2.5e-10
  .? .....?
3.125e-10
  .? .....?
```

If the Waveform simulator progress indicator contains more than one exclamation mark per 50 or so progress points (10 progress points on each alternate line) then the over-relaxation factor should be changed from the default value of 1.8 to 1.0. The sensible values for this factor range from 1.0 to just under 2.0. Every time the software internally reduces the magnitude of the over-relaxation factor, an exclamation mark is posted on the display of the progress. The modification of the over-relaxation factor is defined in the SWEEP block as follows:

```
SWEEP
time_s1 LIN 0 1e-9 1e-12 options orfactor=1.0
```

19. Use of “include” files

Data in other files can be included in the netlist file through the use of the INCLUDE statement. A particularly useful application of this capability is the inclusion of the file or files containing the non-linear model parameters. The waveform parser will replace the line containin the INCLUDE keyword with the complete contents of the file specified after the INCLUDE keyword . As an example of the syntax, the following is used to include the data in the model parameter modparam.inc data file:

```
INCLUDE modparam.inc
```

20. Scaling of diode areas and FET gate widths

The value of any non-linear model parameter can be over-ridden by the explicit assignment of a new value to that parameter in the parameter list for the device instance. For example, if we had:

```
var
sysz0 = 50

model
monofet device=tomfet level=1 cds=18.32125f cgd = 17.0095f &
cgs=37.0095f n=1.94027 is=10.372n vbi=0.839117 delta=6.20952 &
beta=0.0476935 vto=-0.504142 gamma=0.0176 q=1.89791 rg=4.1 &
rs=3.1 rd=4.1

ckt
vsource_vlo 5 0 sin=(0 1.414 14g 0 0) r=sysz0
vsource_vrf 1 0 sin=(0 0.33 12.5g 0 0) r=sysz0
res_rifterm 6 0 r=sysz0
cap_crfmatch 1 2 c=35f
cap_clomatch 4 5 c=140f
cap_ciffilter 6 0 c=1n
ind_lrfmatch 2 0 l=450p r=1
ind_llomatch 5 0 l=200p r=1
ind_liffilter 4 6 l=1n r=1
monofet_fet1 4 2 0 rd=10
DEFOP TEST

sweep
time_s1 lin 0 22e-9 5e-12
```

we would over-ride the $rd=4.1$ in the monofet model parameter set with the new value $rd=10$, as defined in the element instance parameter set. In like manner, the scaling of the active devices is performed. The allowed parameters and keywords used to indicate device size and (for FETs) the number of fingers varies from model to model. The parameters are as follows:

```
SPICEdiode_123 1 2 area=10
```

```
EEHEMT_123 1 2 0 AGW=100e-6 AGF=2
```

```
GFET3_123 1 2 0 NF=2 SCL=100
```

```
TOMFET_123 1 2 0 width=100e-6
```

In the element schematic, simply add the additional parameters as shown above to the element schematic to indicate a different gate width (for example) relative to the actual device.

21. WaveForm Devices

CAP	Capacitance
-----	-------------

DIODE	Diode (Standard SPICE Diode)
-------	---------------------------------

FET	EEHEMT (EESof GaAs HEMT model)
-----	-----------------------------------

FET	GFET3 (restricted access model)
-----	------------------------------------

FET	TOMFET (GaAs FET Triquint Own Model)
-----	---

IND	Inductance
-----	------------

ISOURCE	Independent current source DC PULSE PWL (Piece Wise Linear) SINE
---------	--

RES	Resistance
-----	------------

SNP	N Port S Parameter Impulse Response (N = 1 to 9)
-----	---

TLINE	Transmission line with DC (frequency independent) loss.
-------	--

VCCS	Voltage Controlled Current Source
------	-----------------------------------

VCVS	Voltage Controlled Voltage Source
------	-----------------------------------

VSOURCE	Independent voltage source DC
---------	----------------------------------

PULSE
PWL (Piece Wise Linear)
SINE

CAP

Capacitance

Device name capacitance
Minimum name c

Ports: 2
 P1 (order not important)
 P2 (order not important)

Parameters

name	short name	description	default value	max	min	need	can be zero
capacitance	c	capacitance	-	-	-	✓	✓
resistance	r	series resistance	-	-	0.1	✓	*

Note:

1. In a linear simulation, this element is defined as a SRC element.

The screenshot shows the WaveMaker 4.380 SLAC interface. On the left, a circuit diagram is displayed with two ports, P1 (labeled 1) and P2 (labeled 2). The circuit consists of a capacitor and a resistor connected in series. On the right, the parameters for the CAP element are listed:

```
NETNAME=CAP_TRAN  
C=  
R=1.0  
I1B=TBD  
LINEAR=1  
NONLIN=1  
SIM=SIM  
LAY=NOLAY  
MIR=0  
DAB=NULL  
CID=
```

The bottom right corner of the window shows the label 'VMAX'.

DIODE

Device name diode
Minimum name d

Ports: 2
P1 = cathode (negative electrode)
P2 = anode (positive electrode)

Parameters

name	short name	description	default value	max	min	needed	can be zero
area	a	Relative area	1	-	0	x	x
is	isr	saturation current	1e-14	-	0	x	x
isr	isr	recombination current parameter	0	-	0	x	✓
rs	r	series ohmic resistance	0	-	0.1 if not 0	x	✓
n	n	ideality	1	-	0	x	x
nr	nr	emission coefficient for isr	2	-	0	x	x
tt	tt	transit time	0	-	0	x	✓
cjo	c	zero bias capacitance	0	-	0	x	✓
vj	v	junction potential	1	-	0	x	x
m	m	grading coefficient	0.5	-	0	x	✓
eg	e	bandgap	1.11	-	0	x	x
xti	x	temperature exponent	3	-	-	x	✓
fc	f	fwd. depletion cap. coeff.	0.5	1	-	x	✓

bv	bv	breakdown voltage	0.5	-	0	x	✓
ibv	ibv	current at bv	1e-10	-	0	x	x
ibv1	ibv1	low-level breakdown knee curr.	0	-	0	x	✓
nbv	nbv	breakdown ideality	1	-	0	x	x
nbv1	nbv1	low-level breakdown ideality	1	-	0	x	x
ikf	ik	high injection knee current	0	-	0	x	✓
tikf	ti	tempco of ikf	0	-	-	x	✓
tbv1	tbv1	bv linear tempco	0	-	-	x	✓
tbv2	tbv2	bv quadratic tempco	0	-	-	x	✓
trs1	trs1	rs linear tempco	0	-	-	x	✓
trs2	trs2	rs quadratic tempco	0	-	-	x	✓
tactual	ta	actual temperature	27°C	-	0	x	x
Tnominal	tn	nominal temperature	27°C	-	0	x	x

Note:

1. The following scale with area:

is, isr, cjo, ibv, ibv1, ikf

2. The following scale inversely with area:

rs

The value of rs after scaling must be greater than 0.1 if it is not 0.

3. The value for the I1B bias current will be worked out by the software from the data in the .raw data file after a d.c. or time domain simulation has been performed.

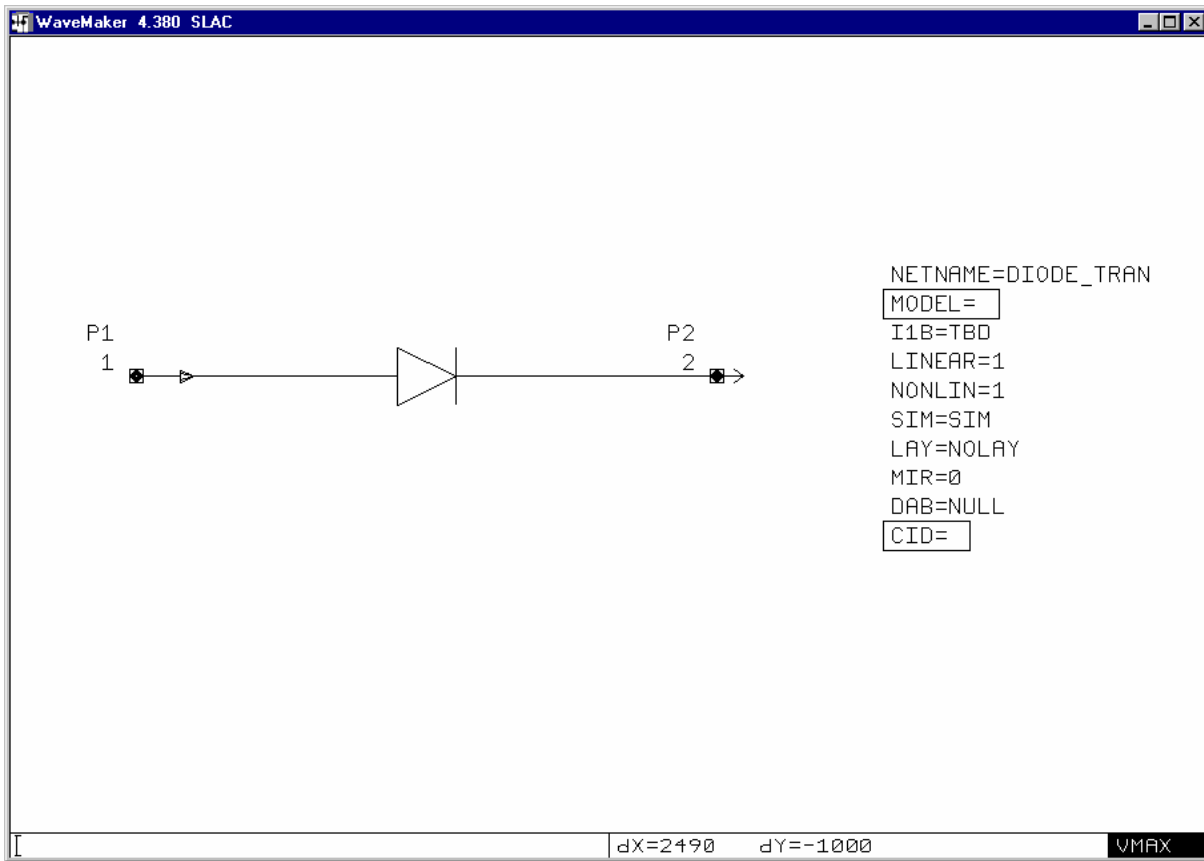

FET**HP EEsof EEHEMT1 GaAs HEMT model**

Device name eehemt
 Minimum name ee

Terminals: 3
 P1 = gate
 P2 = drain
 P3 = source

Parameters

name	short name	description	default value	max	min	need	can be zero
ugw	u	Unit gate width	1.0	-	-	x	✓
ngf	ng	Number of gate fingers	1	-	1	x	x
vto	vto	Zero bias threshold	-1.5	-	-	x	x
gamma	gamma	Vds dependent threshold	0.05	-	-	x	x
vgo	vg	Vgs for peak Gm	-0.5	-	-	x	x
vdelt	Vdelt	not used	0.0	-	-	x	x
vch	vch	Vgs at which gamma vanishes	1.0	-	-	x	x
gmmax	gmmax	Peak Gm	0.7	-	-	x	x
vdso	vd	Vds at which Vo dependence vanishes	2.0	-	-	x	x
vsat	vs	Drain source current saturation voltage	1.0	-	-	x	✓
kapa	kapa	Output conductance parameter	0.0	-	-	x	x
peff	peff	Self-heating parameter	2.0	-	-	x	✓
vtso	vtso	Subthreshold onset voltage	-10.0	-	-	x	x

vco	vc	Voltage where Gm compression occurs for Vds = vdso	10.0	-	-	x	x
mu	m	Vds Gm compression parameter	0.0	-	-	x	x
vba	vba	Gm compression tail-off	1.0	-	-	x	x
vbc	vbc	Gm roll-off to tail-off transition	1.0	-	-	x	x
deltgm	deltgm	Slope of Gm compression characteristic	0.0	-	-	x	x
alpha	al	Gm saturation to compression transition parameter	0.001	-	-	x	x
rdb	rdb	Dispersion source output impedance	1.0e9	-	-	x	x
cbs	cb	Trapping state capacitance	1.6e-12	-	-	x	x
gdbm	gd	Additional d-b branch conductance at Vo = vds	0.0	-	-	x	x
kdb	kd	Vds d-b branch conductance parameter	0.0	-	-	x	x
vds	vds	Voltage at which d-b branch conductance is constant	1.0	-	-	x	x
gmaxAC	gmaxa	AC gmax	0.6	-	-	x	x
vdeltAC	Vdelta	notused	0.0	-	-	x	x
vtoAC	vtoa	AC vto	-1.5	-	-	x	x
gammaAC	gammaa	AC gamma	0.05	-	-	x	x
kapaAC	kapaa	AC kapa	0.0	-	-	x	x
peffAC	peffa	AC peff	10.0	-	-	x	✓
vtsoAC	vtsoa	AC vtso	-10.0	-	-	x	x
deltgmAC	deltgma	AC deltg	0.0	-	-	x	x
cllo	cllo	Maximum Cin for Vds = vdso and vdso > deltds	3.0e-12	-	-	x	x

c11th	c11t	Threshold Cin for Vds = vds0	0.3e-12	-	-	x	x
vinfl	vi	Inflection point in C11-Vgs characteristic	-1.0	-	-	x	x
deltgs	deltgs	C11th to c11o transition voltage	0.5	-	-	x	✓
delt ds	delt d	Linear to saturation transition parameter	1.0	-	-	x	✓
lambda	la	C11-Vds characteristic slope paramter	0.05	-	-	x	x
c12sat	c12s	Input transcapacitance for Vgs = vinfl and Vds > deltds	0.3e-12	-	-	x	x
cgdsat	cg	Ggd for Vds > deltds	0.5e-12	-	-	x	x
c12o	ca2o	Not used	0.0	-	-	x	x
c11delt	c11d	Not used	0.0	-	-	x	x
ris	ris	Source end channel resistance	2.0	-	0.1 if not 0	x	✓
rid	rid	Drain end channel resistance	0.0	-	0.1 if not 0	x	✓
tau	t	Not used	1.0e-12	-	-	x	x
cdso	cd	Inter-electrode Cds	0.8e-12	-	-	x	x
is	is	Gate saturation current	1.0e-20	-	-	x	x
n	n	Gate ideality	1.0	-	-	x	x
kbk	kb	Breakdown current coeff. At threshold	0.0	-	-	x	x
idsoc	id	Open channel Ids	1.0	-	-	x	✓
vbr	vbr	Vdg breakdown voltage	15.0	-	-	x	x
nbr	nb	Breakdown current exponent	2.0	-	-	x	x

rd	rd	Drain contact resistance	-	-	0.1 if not 0	x	✓
rs	rs	Source contact resistance	-	-	0.1 if not 0	x	✓
rg	rg	Gate metallisation resistance	-	-	0.1 if not 0	x	✓
ld	ld	Drain series inductance	0	-	-	x	✓
ls	ls	Source series inductance	0	-	-	x	✓
lg	lg	Gate series inductance	0	-	-	x	✓
cpgs	cpg	Parasitic gate source capacitance	-	-	-	x	✓
cpds	cpd	Parasitic drain source capacitance	-	-	-	x	✓
tactual	ta	Actual temperature	27°C	-	0	x	✓
tnominal	tn	Nominal temperature	27°C	-	0	x	✓

Note:

1. There is a scaling factor, called sf, where:

$$sf = ugw * ngf$$

2. The following scale as sf:

is, gmmax, gmmaxac, deltgm, deltgmac, peff, peffac, gdbm, kbk, idsoc, cbs, c11o, c11th, c12sat, cgdsat, cdso

3. The following scale inversely as sf:

Ris, rid, rdb, rs, rd, kdb

4. Rg scales as:

ugw / ngf

5. The scaled values of ris, rid, rdb, rs, rd, rg must be greater than 0.1 if they are not 0.

6. The dispersion elements rdb and cbs do not appear in the circuit. They are merely used to define the time constant. Setting either of these to 0 will disable the dispersion model and only the DC values will be used.

7. The parameters Cpgs and Cpds are extensions to the EEHEMT1 model and are bias and scaling independent capacitors connected between the **internal** nodes of the FET (inside the series elements).

8. By default, to conform with the EEsof implementation, the series inductance values are ignored. Setting either of the additional parameters, cpgs or cpds, will enable the extended model, and the inductance values will then be used.

9. The value for the IgB, IdB and IsB gate, drain and source bias currents respectively will be worked out by the software from the data in the .raw data file after a d.c. or time domain simulation has been performed.

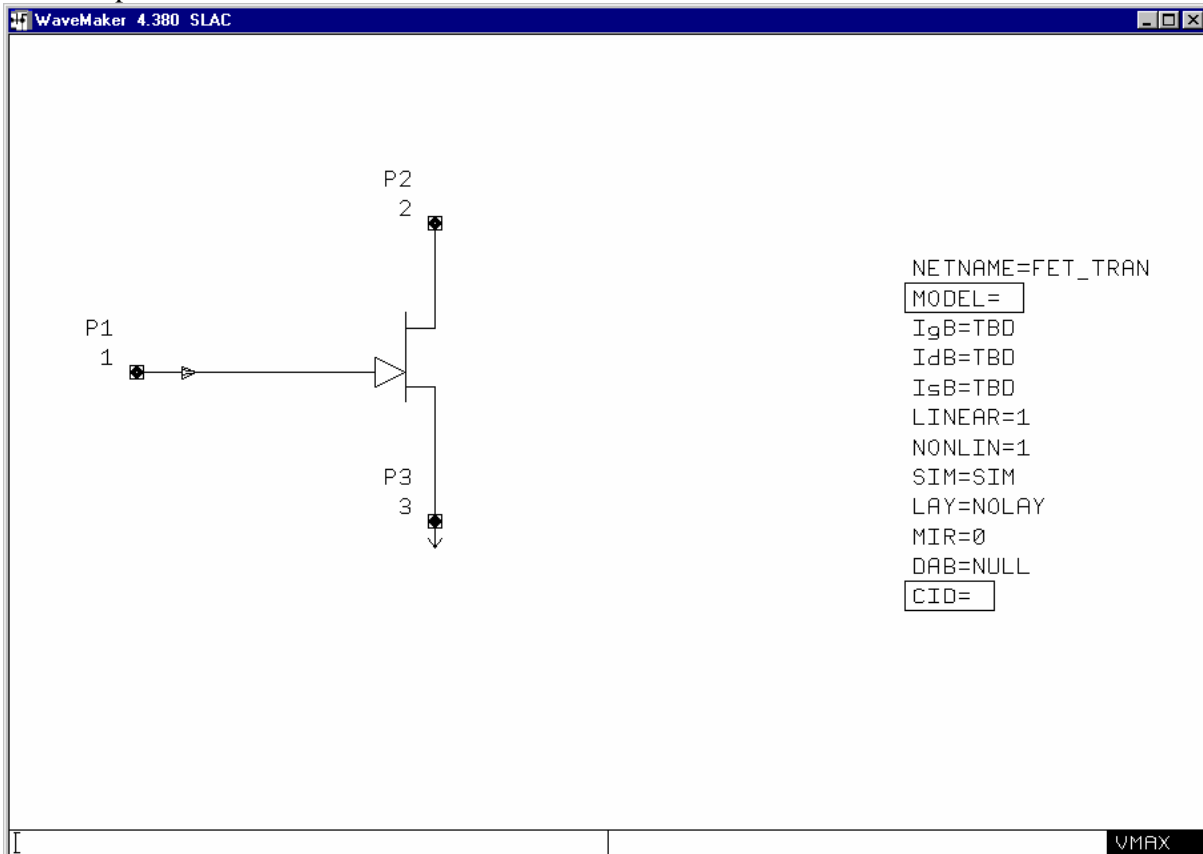

The extensions to the EEHEMT1 model are shown schematically as:

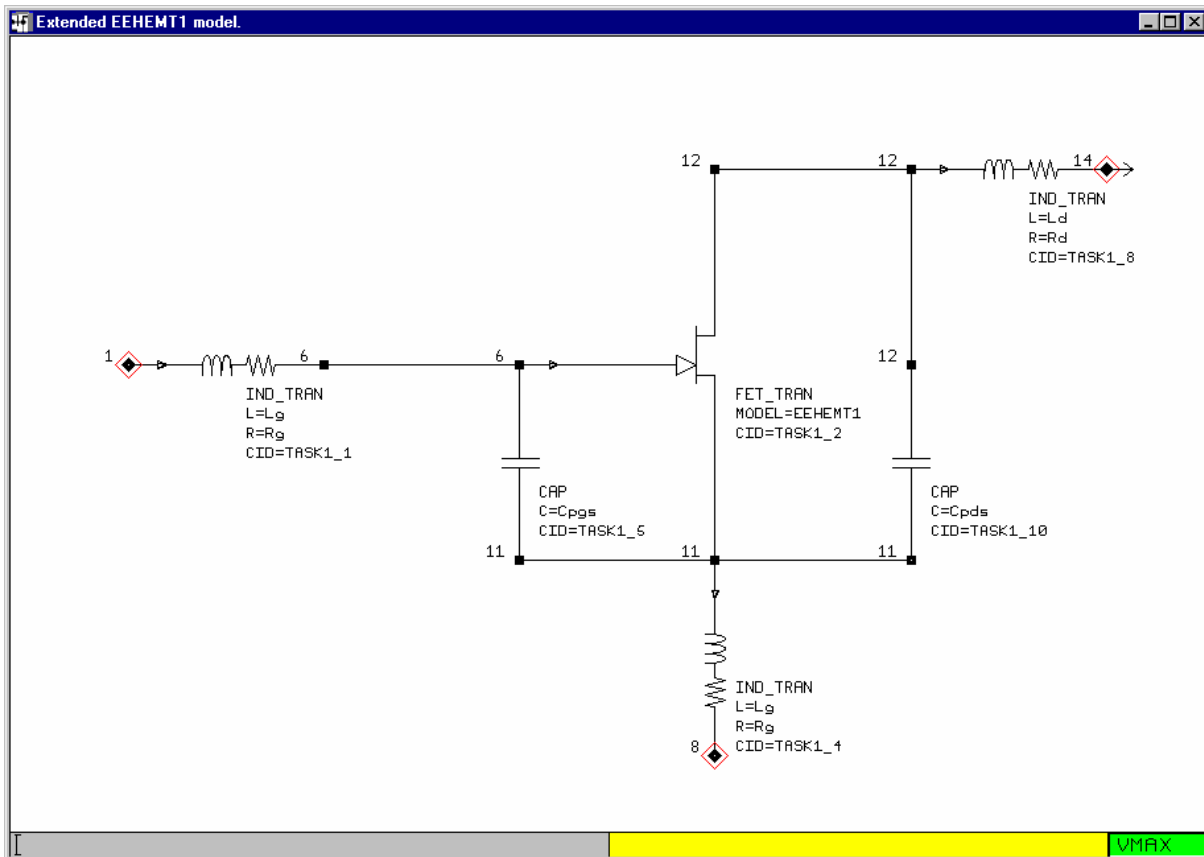

If a value is given to either the Cpgs or Cpds elements, then the software assumes the extended EEHEMT1 model is to be used. Note that the elements in the extended circuit are independent of scaling with different gate widths. An example of the use of the extended parameters is as follows:

```
! GEC MMT H40 process PHEMT parameters for 1 finger x 24um finger width
H40F1x24 device=EEHEMT level=1 UGW=24E-6 NGF=1 &
  Vto=-1.15 Gamma=0.0518 Vgo=-0.250 Vch=0.816 GmMax=0.0128 Vdso=2.0 &
  Vsat=0.801 Kapa=0.0037 Peff=1.14 Vtso=-10 Vco=-0.588 Mu=0.0015 Vba=0.501 &
  Vbc=0.697 Deltgm=0.00775 Alpha=0.236 Rdb=6e9 Cbs=2.7e-14 Gdbm=6.98e-4 &
  Vdsm=0.633 GmMaxAC=0.01538 VtoAC=-1.17 KapaAC=-0.0344 PeffAC=1.14 &
```

```
GammaAC=0.0235 Kdb=149.0 VtsoAC=-10 DeltgmAC=0.00943 Is=0.62e-10 N=1.85 &
Kbk=1.8e-8 Idsoc=0.013 Vbr=3.5 Nbr=5.0 Rs=10.29 Rg=2.138 Rd=23.14 &
Ls=4.5e-12 Lg=20.89e-12 Ld=18.36e-12 C11o=28.42e-15 C11th=9.77e-15 &
Vinfl=-0.890 Deltgs=2.8 Deltds=0.529 Lambda=0.150 C12sat=5.02e-15 &
Cgdsat=3.96e-15 Cdso=5.52e-15 Ris=22.7 Rid=22.7 Tau=0e-12 &
Cpgs=13.8e-15 Cpds=7.73e-15
```

FET

GFET3 model

Device name	GFET3
Minimum name	GF
Terminals:	3
	P1 = gate
	P2 = drain
	P3 = source
Parameters	

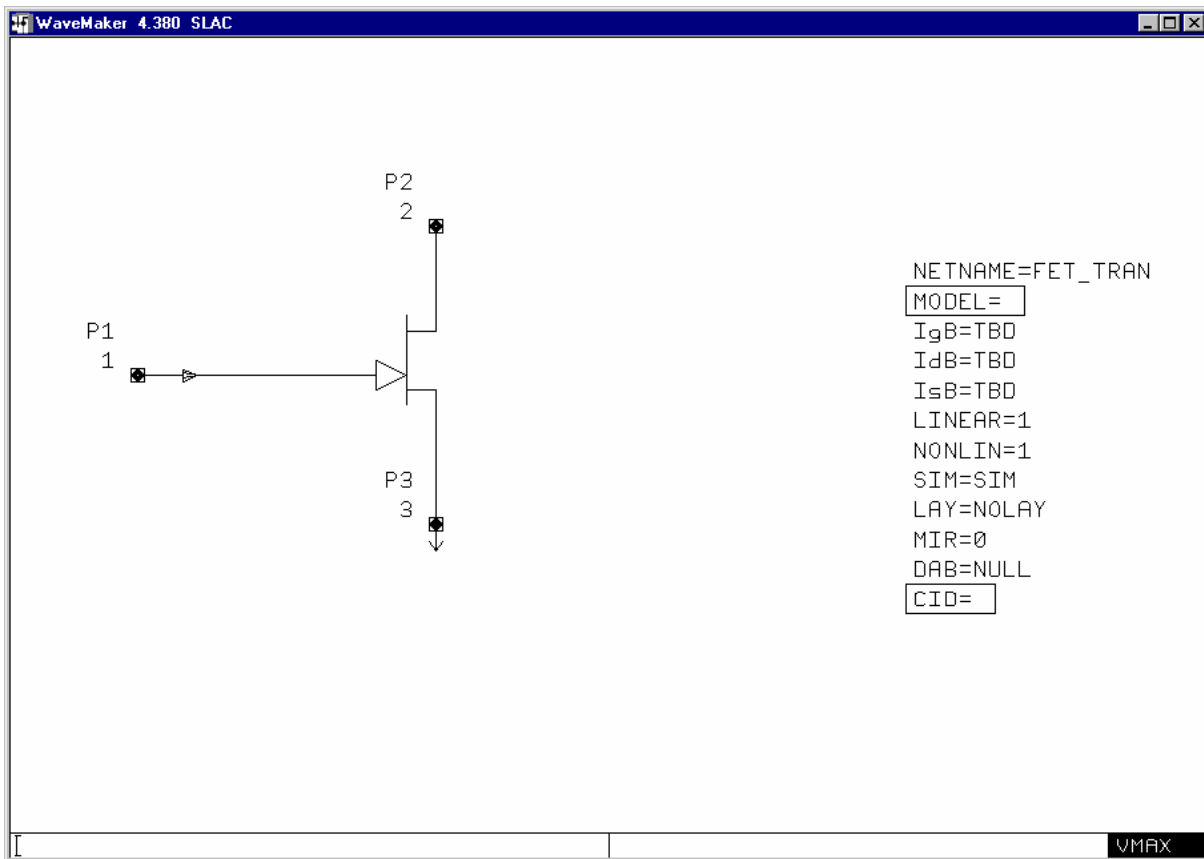

Note:

1. This is a proprietary, restricted access model.
2. The value for the IgB, IdB and IsB gate, drain and source bias currents respectively will be worked out by the software from the data in the .raw data file after a d.c. or time domain simulation has been performed.

FET

Device name tomfet
 Minimum name to

Ports: 3
 P1 = gate
 P2 = drain
 P3 = source

Triquint Own Model (TOM)

Parameters

name	short name	description	default value	max	min	need	L1	L2	L3	can be zero
level	l	model level 1, 2 and 3	1	3	1	x	✓	✓	✓	x
width	w	Relative width	1	-	0	x	✓	✓	✓	x
alpha	a		2	-	0	x	✓	✓	✓	x
beta	beta	transconductance coefficient	0.1	-	0	x				x
betatce	betat	beta exponential tempco	0	-	-	x				✓
cds	cds	drain-source cap.	0	-	0	x				✓
cgd	cgd	zero-bias gate-drain cap.	0	-	0	x				✓
cgs	cgs	zero bias gate-source cap.	0	-	0	x				✓
eg	e	bandgap	1.11	-	0	x				x
fc	fc	depletion cap. coefficient	0.5	1	0	x				x
is	is	gate saturation current	1e-14	-	0	x				✓
n	n	gate ideality	1	-	0	x				x
rd	rd	parasitic drain resistance	0	-	0.1 if not 0	x				✓
rg	rg	parasitic gate resistance	0	-	0.1 if not 0	x				✓
rs	rs	parasitic source resistance	0	-	0.1 if not 0	x				✓

trdl	trd	rd linear tempco.	0	-	-	x				✓
trgl	trg	rg linear tempco.	0	-	-	x				✓
trsl	trs	rs linear tempco.	0	-	-	x				✓
vbi	vbi	gate barrier height	1	-	0	x				x
vto	vto	gate turn-on voltage	-2.5	-	-	x				✓
vtotce	vtot	vto exponential tempco.	0	-	-	x				✓
xti	x	is temperature exponent	0	-	-	x				✓
b	b	doping tail parameter	0	-	0	x				✓
lambda	l	channel length modulation	0	-	-	x				✓
m	m	gate grading coefficient	0.5	-	0	x				✓
tau	ta	conduction current delay	0	-	0	x				✓
vdelta	vd	capacitance transition voltage	0.2	-	-	x				✓
vmax	vm	capacitance limiting voltage	0.5	-	-	x				✓
delta	d	output feedback parameter	0	-	-	x				✓
gamma	gamma	static feedback parameter	0	-	-	x				✓
q	q	power law parameter	2	-	0	x				x
nd	nd	subthreshold slope drain parameter	0	-	-	x				✓

ng	ng	subthreshold slope gate parameter	0	-	-	x				✓
alphanat	alphanat	alpha exponential temperature coefficient	0	-	-	x				✓
cgdtce	cgdt	cgd temperature coefficient	0	-	-	x				✓
cgstce	cgst	cgs tempco.	0	-	-	x				✓
gammatce	gammat	gamma tempco.	0	-	-	x				✓
tactual	ta	actual temperature	27°C	-	0	x				x
Tnominal	tn	nominal temperature	27°C	-	0	x				x

Note:

1. The level parameter can currently take the following values:

1 = TOM model
2 = TOM2 model
3 = TOM3 model

2. The following scale with width:

is, beta, cgd, cgs, cds, rg

3. The following scale inversely with width:

rs, rd

4. The values of rs, rg, and rd after scaling must be greater than 0.1 if they are not 0.

5. The gate electrode is closer to the source electrode than to the drain electrode, as shown in the schematic.

6. The value for the IgB, IdB and IsB gate, drain and source bias currents respectively will be worked out by the software from the data in the .raw data file after a d.c. or time domain simulation has been performed.

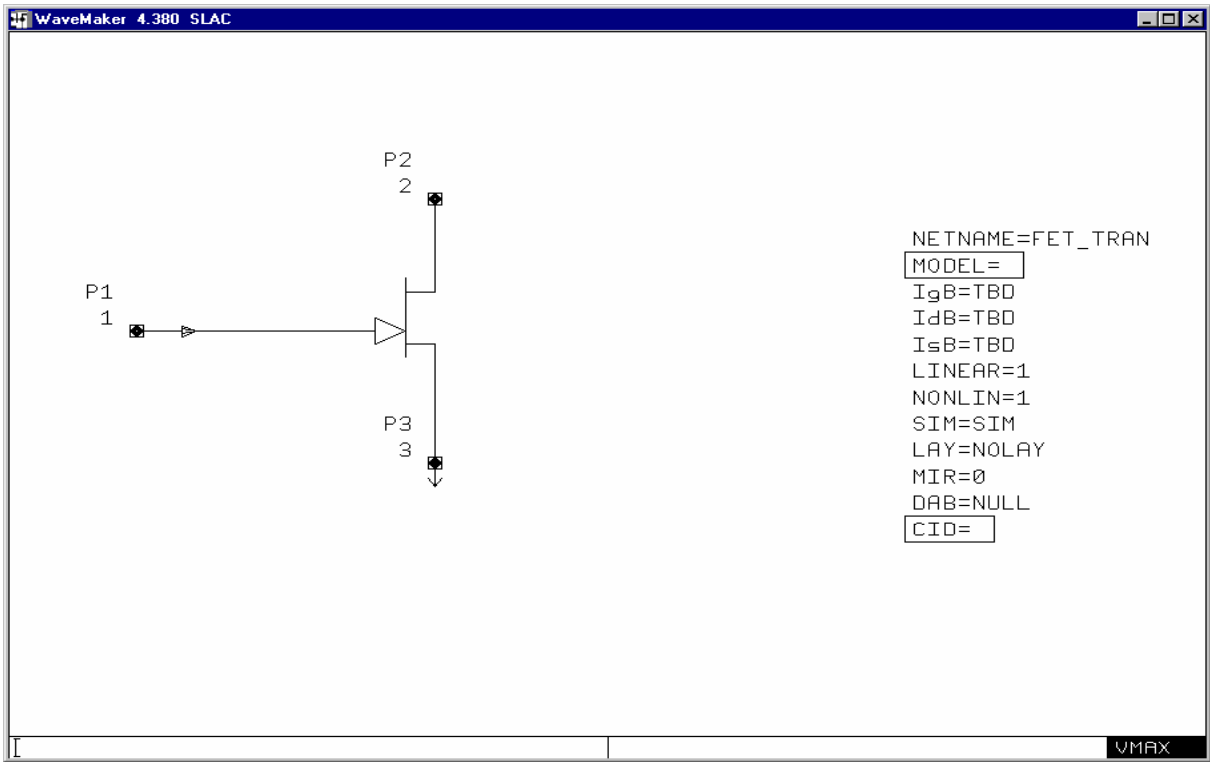

IND

Inductance

Device name inductance
Minimum name in

Ports: 2
 P1 (order not important)
 P2 (order not important)

Parameters

name	short name	description	default value	max	min	need	can be zero
resistance	r	resistance	-	-	0.1	✓	✗
inductance	I or L	inductance	-	-	-	✓	✓

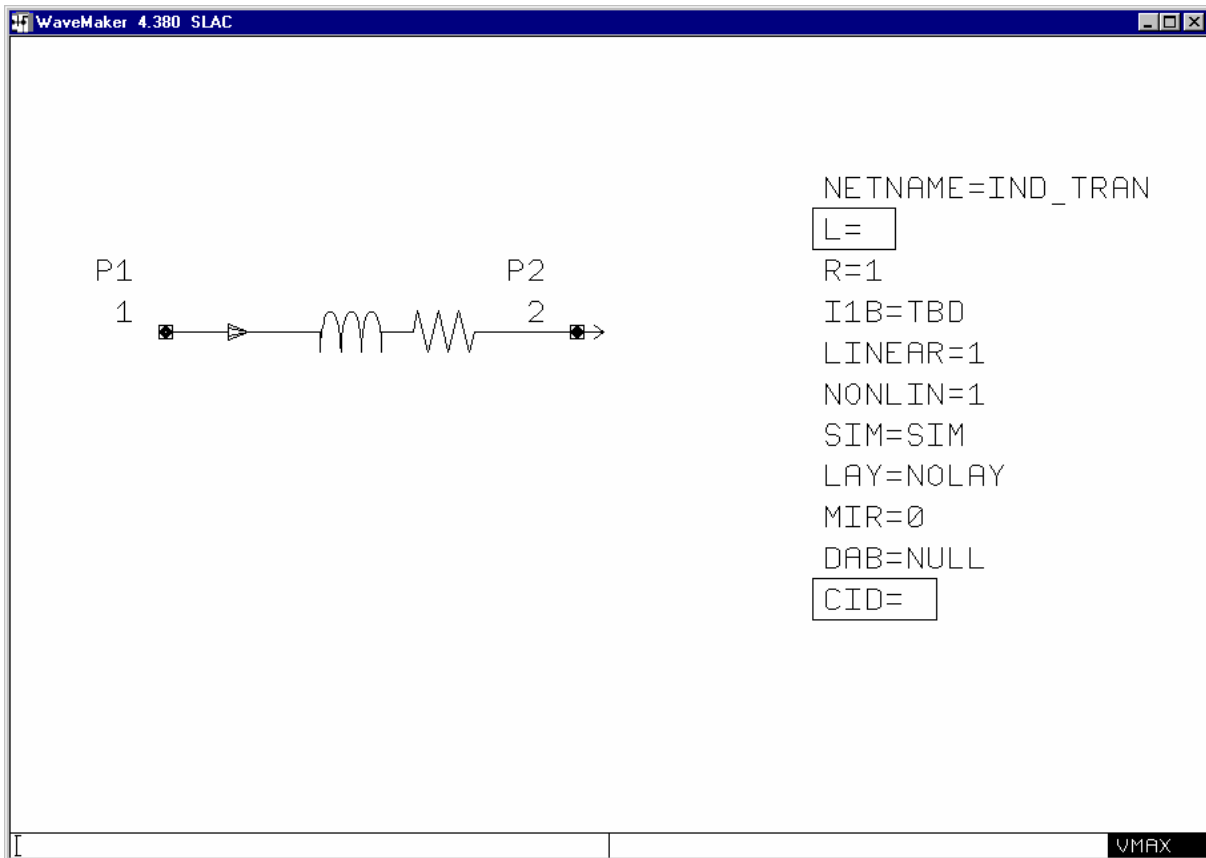

ISOURCE

Independent current source

Device name isource
Minimum name is

Terminals: 2
 P1 = current out
 P2 = current return

Parameters

name	short name	description	default value	max	min	need	can be zero
dc	d	DC current	0	-	-	x	✓
pulse	pu	Pulse (Iinitial, Ipeak, period, width, delay, FallTime, RiseTime)	(0 1 10n 1n 0 1p 1p)	-	-	x	-
pwlfile	pwlfile	"FileName"	-	-	-	x	-
sine	si	Sinusoid (DCoffset, amplitude, frequency, delay, decayTConst)	(0 1 10G 0 0)	-	-	x	-

Note:

1. The pwl file name will currently always be converted to lower case (only important on Unix machines).
2. The simulator also supports the use of piece wise linear pairs of data (PWL), single frequency frequency modulated (SFFM) signals and an exponential (EXP) signal. The syntax is as used in SPICE. These additional features are not supported by the schematic capture.

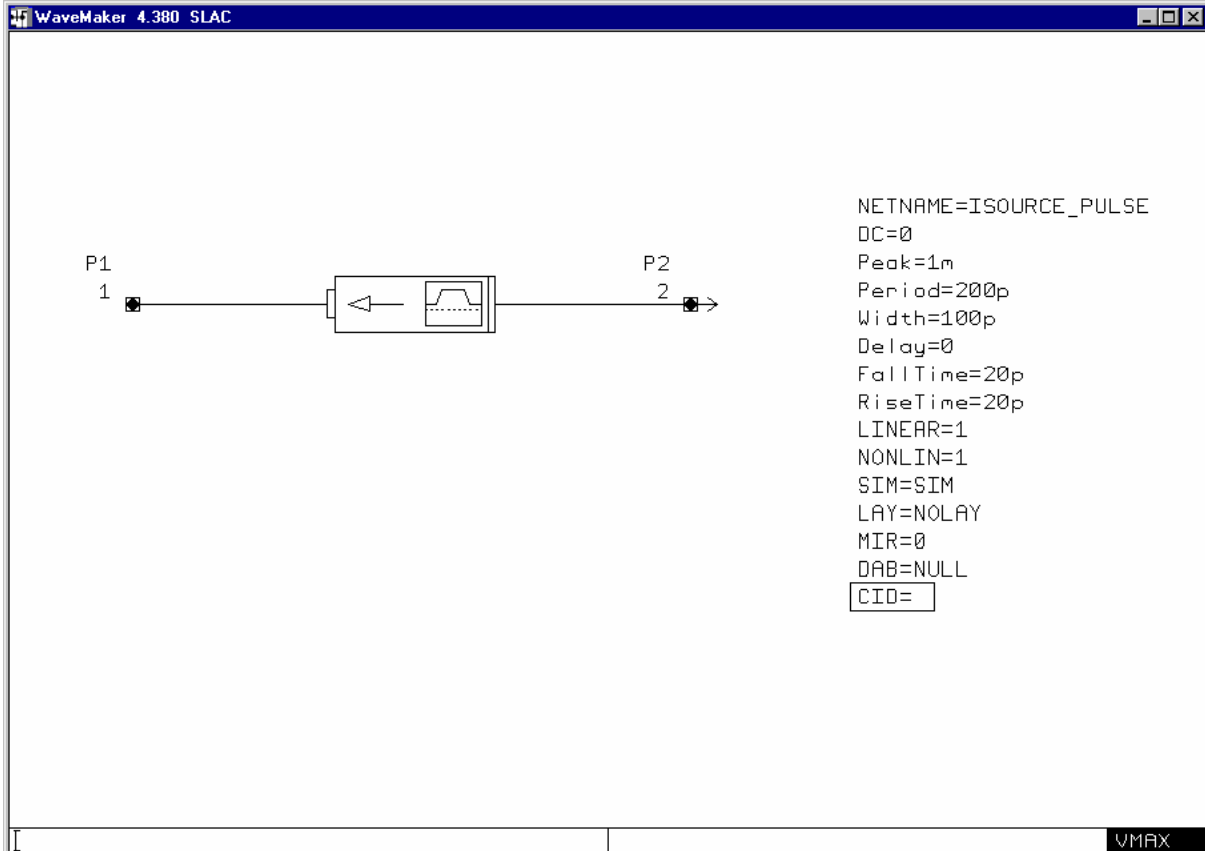
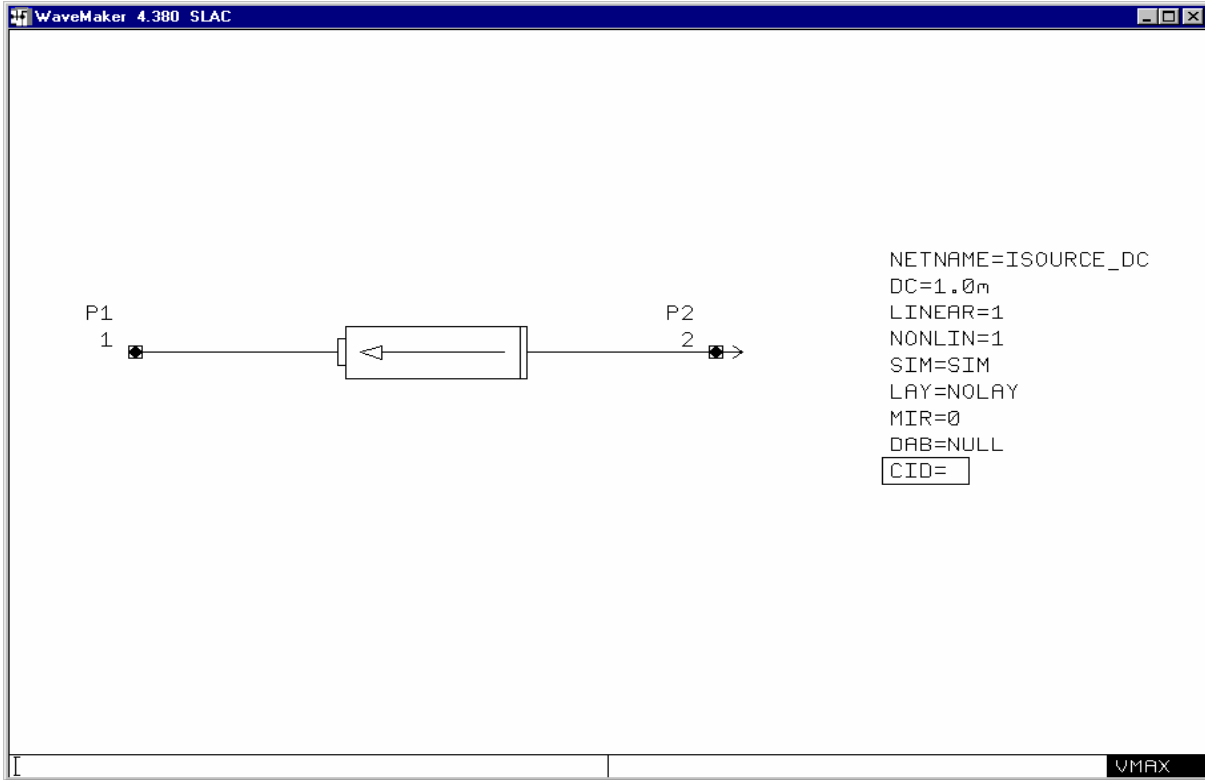

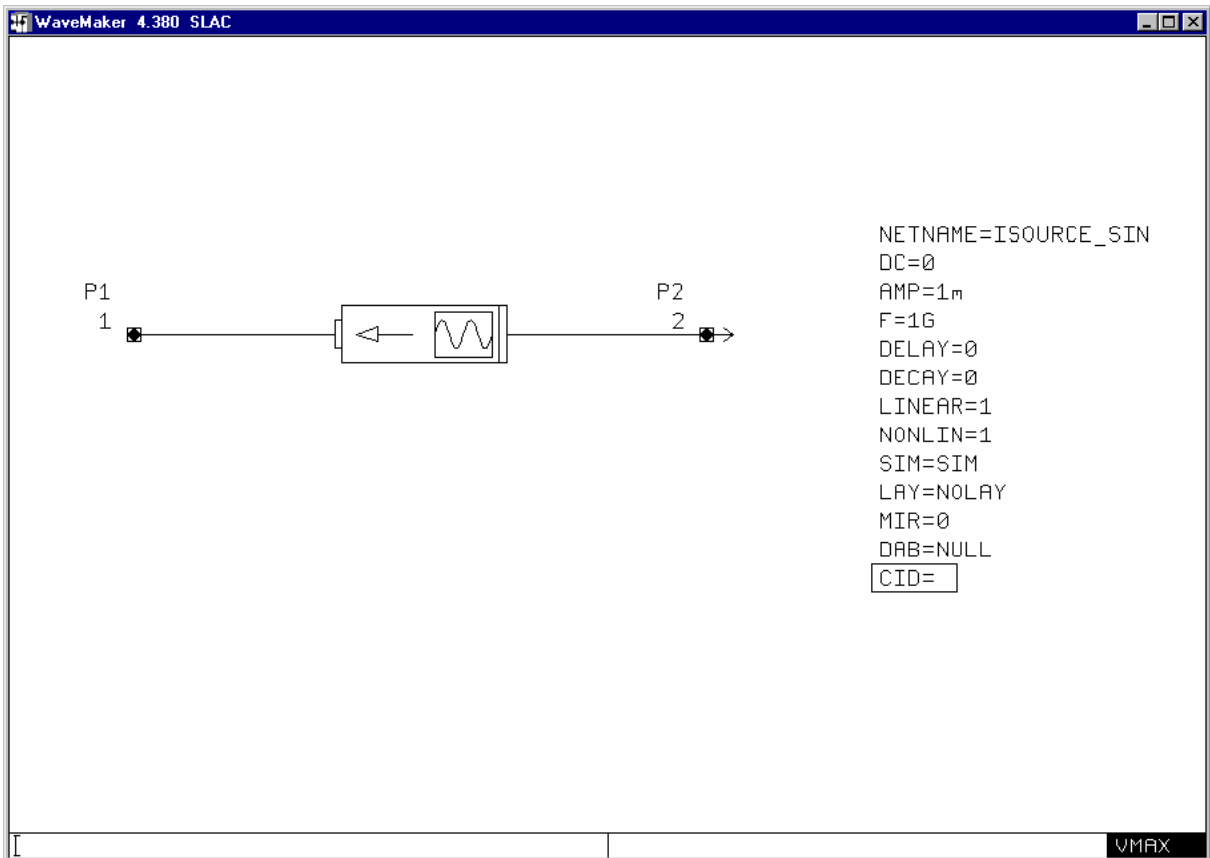
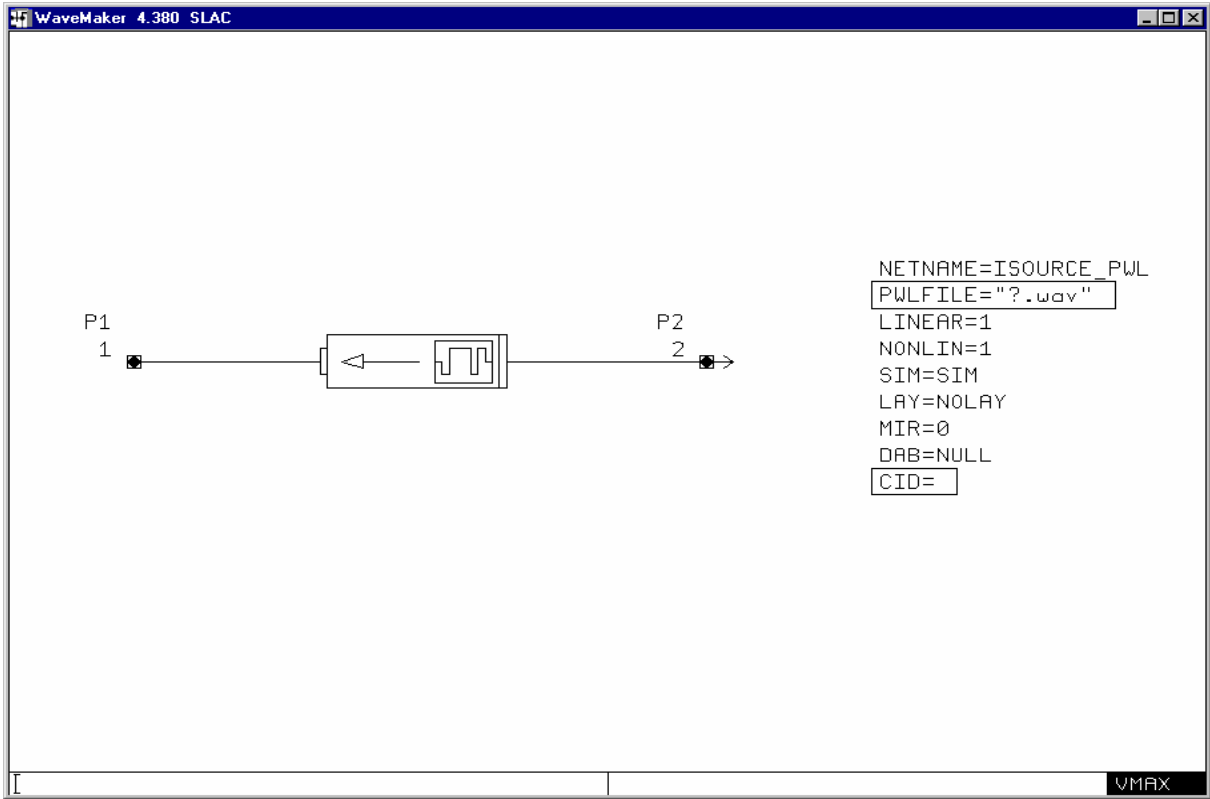

RES**Resistance**

Device name: resistance
 Minimum name r

Ports: 2
 P1 (order not important)
 P2 (order not important)

Parameters

name	short name	description	default value	max	min value	need	can be zero
resistance	r	resistance	-	-	0.1	✓	✗
tc1	tc1	linear tempco	0	-	-	✗	✓
tc2	tc2	quadratic tempco	0	-	-	✗	✓
tcexponent	tce	exponential tempco (%)	0	-	-	✗	✓
tactual	ta	actual temperature	27°C	-	0	✗	✗
Tnominal	tn	nominal temperature	27°C	-	0	✗	✗

Note:

1. tnominal is the base temperature used in calculating temperature dependent values.
 The value used will be:

if (tce = 0)
 then $r = r_{tnom}(1 + tc1(t - tnom) + tc2(t - tnom)^2)$

if (tce ≠ 0)
 then $r = r_{tnom}(1.01^{tce(t - tnom)})$

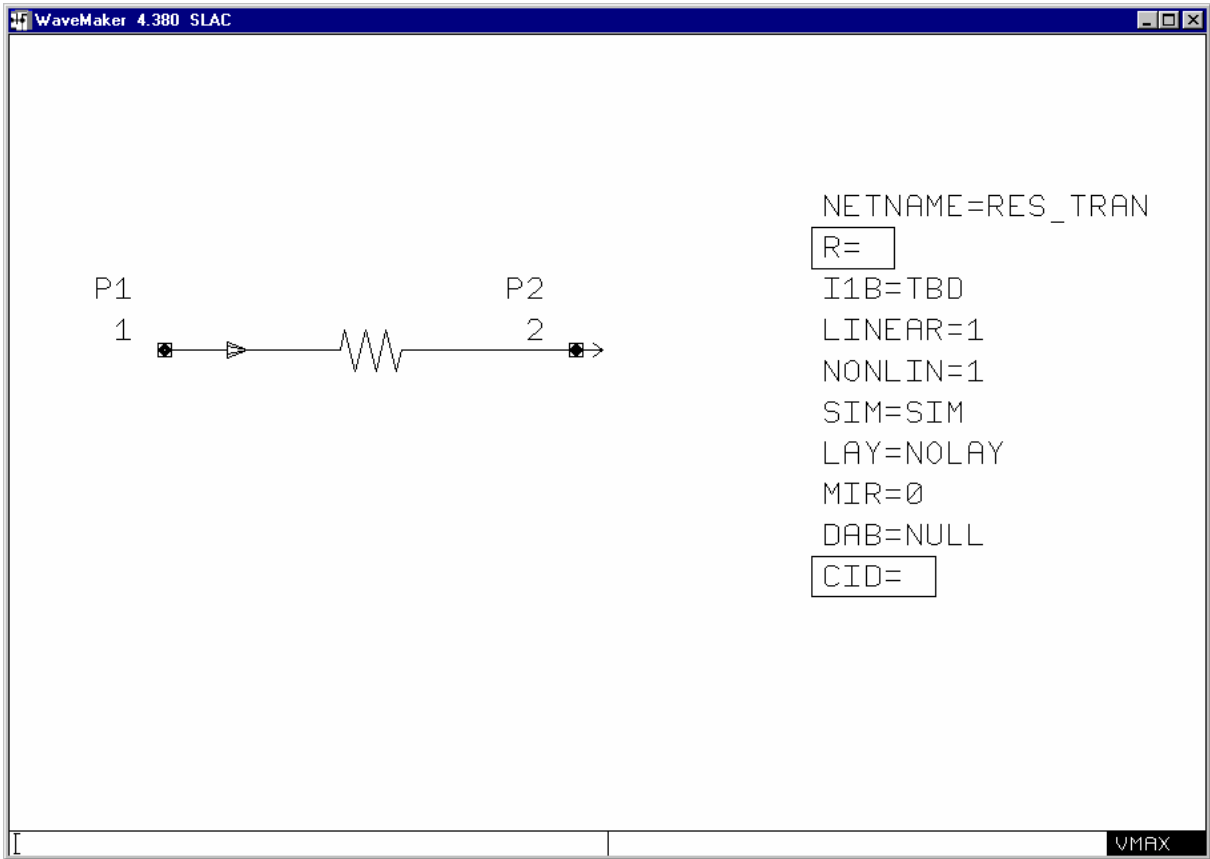

S2P

S parameter impulse response: 2 Port case

Device name s2portimpulse
Minimum name s2

Ports: 4
P1 = p1 in
P2 = p1 return
P3 = p2 in
P4 = p2 return

Parameters

name	short name	description	default value	max	min	need	can be zero
entries	e	number of entries in impulse response	-	-	1	x	x
interval	i	time between entries	0	-	0	x	x
windowtime	windowt	windowing fractional cut-off time	0.8	1	0	x	x
windoworder	windowo	windowing order	2	-	0	x	x
windowfunc	windowf	windowing function	hanning	-	-	x	-
wfifile	wf	Impulse wfi file name (in quotes)	-	-	-	x	-
s11	s11	s11 values vector	-	-	-	x	-
s12	s21	s12 values vector	-	-	-	x	-
s21	s21	s21 values vector	-	-	-	x	-

s22	s22	s22 values vector	-	-	-	x	-
sall	sa	vector of S parameters, S11, S12, S21, S22 per timepoint	-	-	-	x	-

Note:

1. The available windowing functions are hanning and power, and must be entered as strings (surrounded by quotation marks). By default the time-domain windowing is disabled, setting any of the windowing parameters will turn it on. Windowing may be turned off by setting the windowTime >= 1, or by setting the windowing function to none.
2. The impulse response data in a wfi as generated by Impulse is complete and specifying the file name is sufficient, but if a number of entries is separately specified it can be used to override the value given in the file (it can, however, only reduce the number of entries) if only a portion of the impulse response is required. Specifying both the wfi file name and any of interval or any s** will be treated as an error, as they are incompatible.
3. The wfi file name will currently always be converted to lower case (only important on Unix machines).

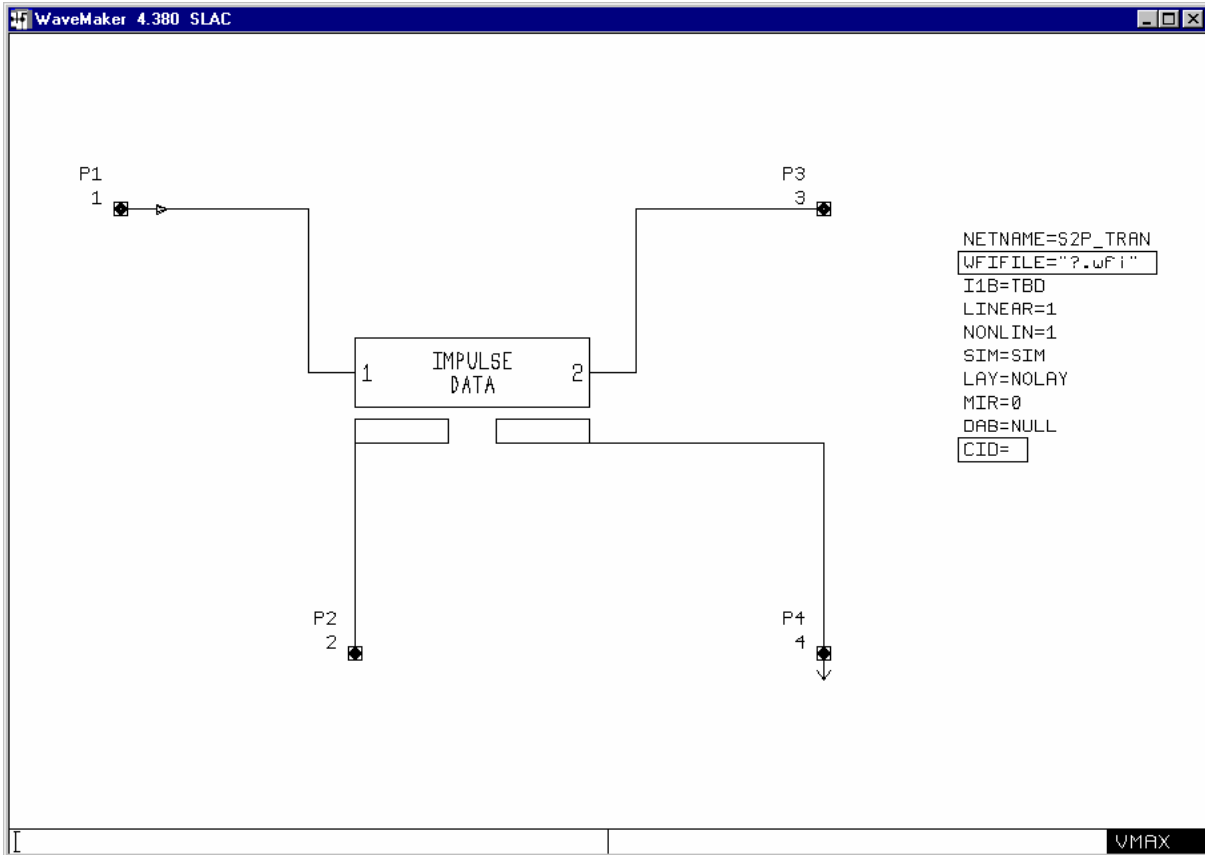

SNP

S parameter impulse response: N Port case, N = 1, 3 to 9

Device name sNportimpulse (N = 1, 3 to 9)
Minimum name sN (N = 1, 3 to 9)

Ports: N + 1
 p1...pN = input1...inputN
 pN+1 = common return

Parameters

name	short name	description	default value	max	min	needed	can be zero
entries	e	number of entries in impulse response	-	-	1	x	x
windowtime	windowt	windowing fractional cut-off time	0.8	1	0	x	x
windoworder	windowo	windowing order	2	-	0	x	x
windowfunc	windowf	windowing function	hanning	-	-	x	-
wfifile	wf	Impulse wfi file name (in quotes)	-	-	-	x	-

Note:

1. The available windowing functions are hanning and power, and must be entered as strings (surrounded by quotation marks). By default the time-domain windowing is disabled, setting any of the windowing parameters will turn it on. Windowing may be turned off by setting the windowTime >= 1, or by setting the windowing function to none.

2. The wfi file name will currently always be converted to lower case (only important on Unix machines).

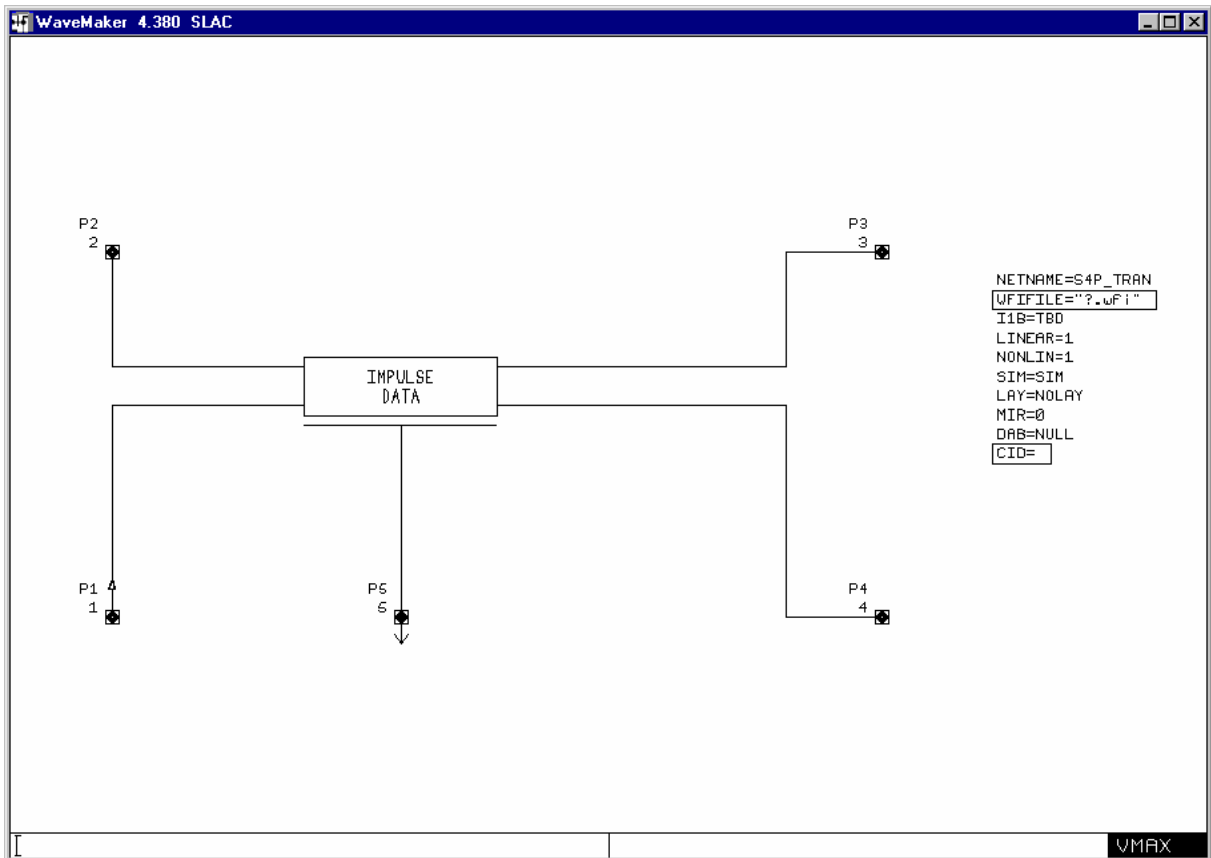

TLINE**Transmission line with DC (frequency independent) loss**

Device name tline

Minimum name tl

Ports: 4
P1 = p1 in
P2 = p1 return
P3 = p2 in
P4 = p2 return

Parameters

name	short name	description	default value	max	min	need	can be zero
delay	d	line delay	-	-	-	✓	✗
z0	z	line impedance	50	-	0	✓	✗
short	s	line is very short	NO	-	-	✗	✓
loss	l	DC loss in dB	0.01	-	-	✗	✓

Note:

1. Loss in dB for the length of line given.

2. The keyword short may be used where the line is very short. Normally the time steps used are forced to be less than the delay along the line, this is usually unwise for very short lines, as the time step would be extremely small, and the interpolation would manage.
3. For the line impedance, you can use z0 or zo, (z “zero” or z “oh”).

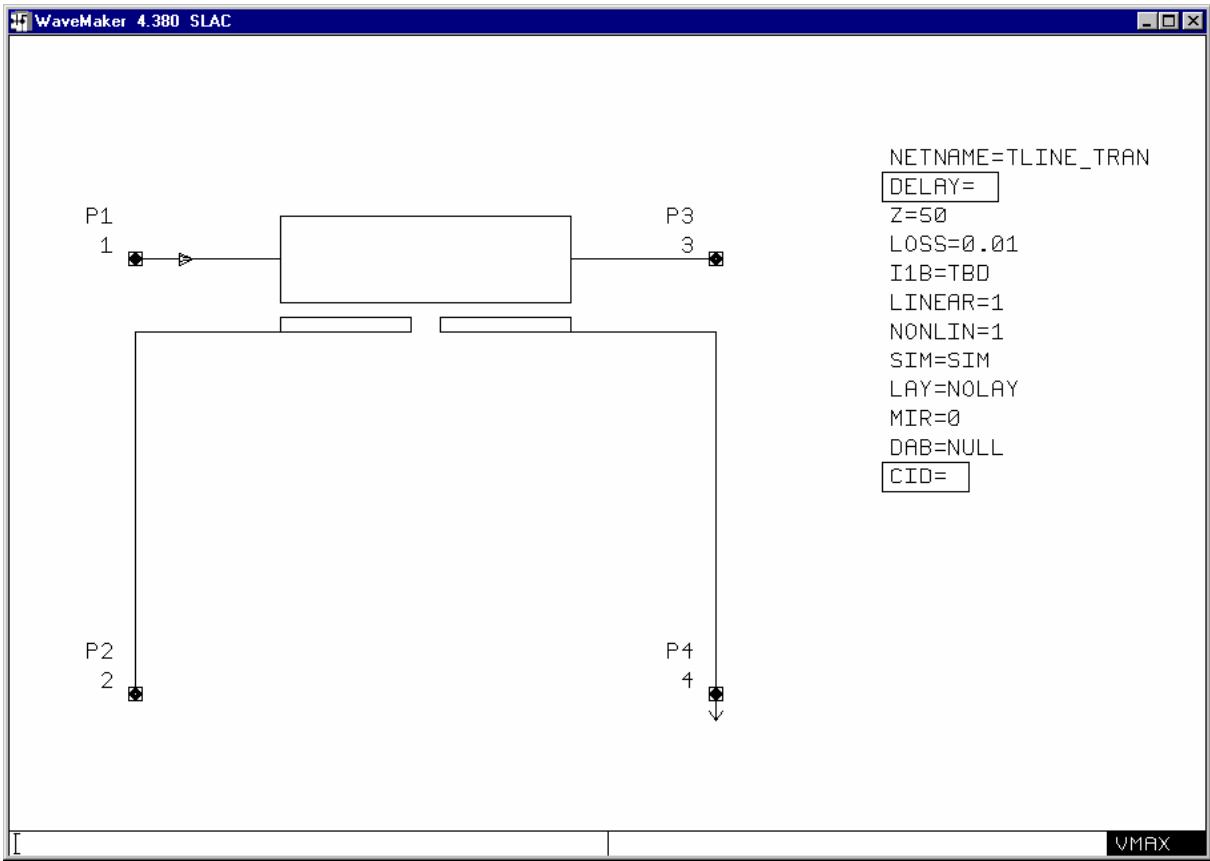

VCCS

Voltage Controlled Current Source

Device name vccs
Minimum name vcc

Ports: 4
P1 = +ve control
P2 = -ve control
P3 = +ve output
P4 = -ve output

Parameters

name	short name	description	default value	max	min	need	can be zero
gm	g	transconductance	1	-	-	x	✓

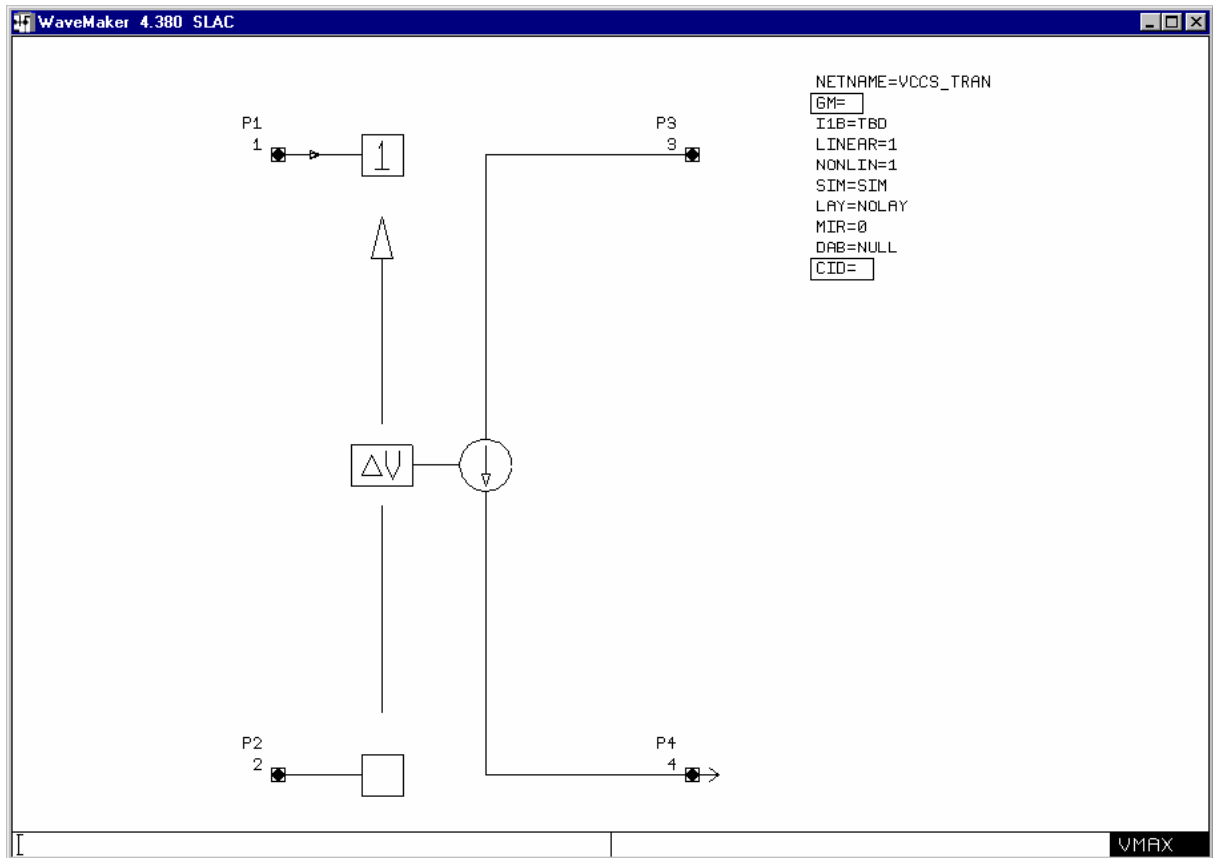

VCVS

Voltage Controlled Voltage Source

Device name vcvs
Minimum name vcvs

Ports: 4

P1 = +ve control
P2 = -ve control
P3 = +ve output
P4 = -ve output

Parameters

name	short name	description	default value	max	min	need	can be zero
resistance	r	series resistance	-	-	0.001	✓	x
gain	g	voltage gain	1	-	-	x	✓

VSOURCE

Independent voltage source

Device name vsource
Minimum name vs

Ports: 2
P1 = current out
P2 = current return

Parameters

name	short name	description	default value	max	min	need	can be zero
resistance	r	series resistance	-	-	0.001	✓	x
dc	d	DC voltage	0	-	-	x	✓
pulse	pu	Pulse (Vinitial, Vpeak, period, width, delay, FallTime, RiseTime)	(0 1 10n 1n 0 1p 1p)	-	-	x	-
pwlfile	pwlfile	"FileName"	-	-	-	x	-
sine	si	Sinusoid (DCoffset, amplitude, frequency, delay, decayTConst)	(0 1 10G 0 0)	-	-	x	-

Note:

1. The pwl file name will currently always be converted to lower case (only important on Unix machines).

2. The simulator also supports the use of piece wise linear pairs of data (PWL), single frequency frequency modulated (SFFM) signals and an exponential (EXP) signal. The syntax is as used in SPICE. These additional features are not supported by the schematic capture.

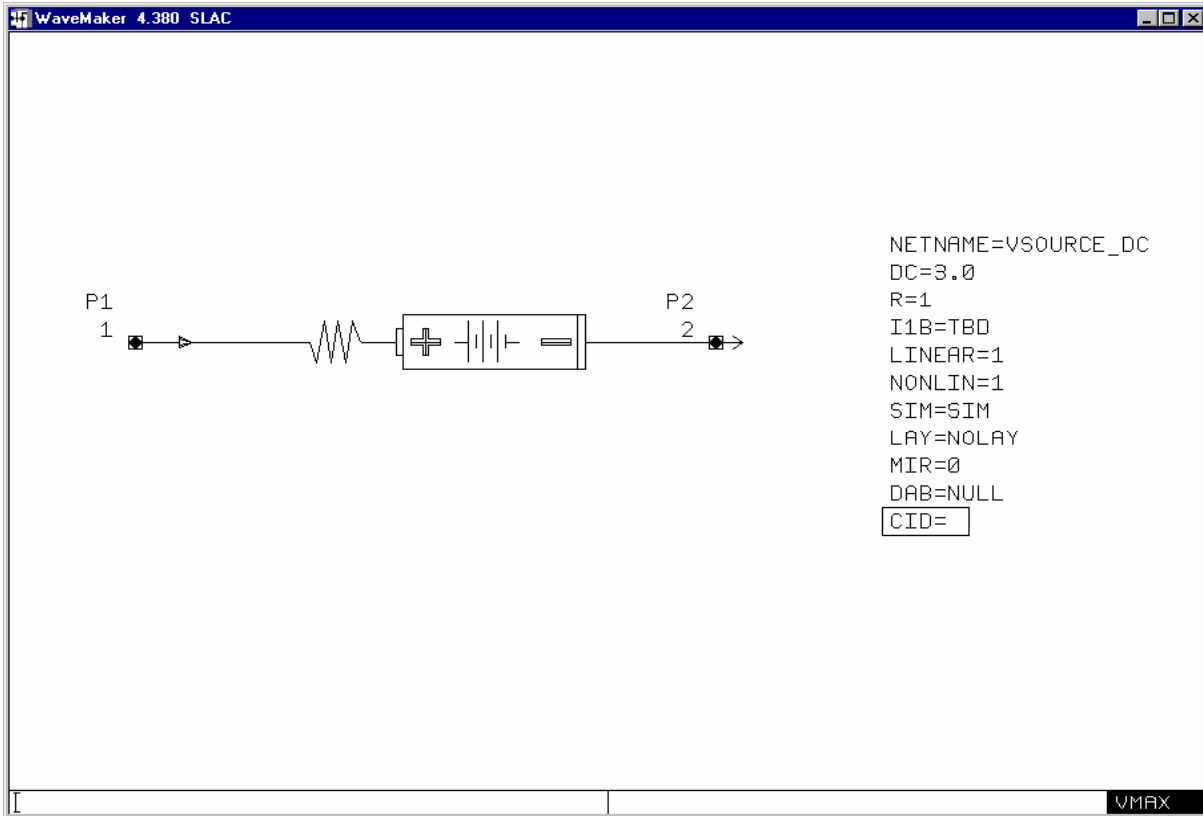

WaveMaker 4.380 SLAC

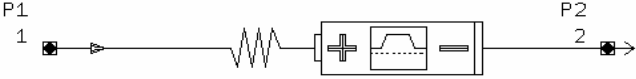

```

NETNAME=VSOURCE_PULSE
DC=0
Peak=1m
Period=200p
Width=100p
Delay=0
FallTime=20p
RiseTime=20p
R=50
I1B=TBD
LINEAR=1
NONLIN=1
SIM=SIM
LAY=NOLAY
MIR=0
DAB=NULL
CID=

```

VMAX

WaveMaker 4.380 SLAC

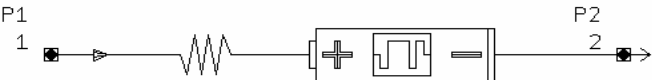

```

NETNAME=VSOURCE_PWL
PWLFILE="?.wav"
R=50
I1B=TBD
LINEAR=1
NONLIN=1
SIM=SIM
LAY=NOLAY
MIR=0
DAB=NULL
CID=

```

VMAX

